

PVMA-1TE-5-1×1-TO39-pSiAR-70

**PRELIMINARY
DATASHEET**

InAsSb one-stage TE cooled photovoltaic multi-junction infrared detector

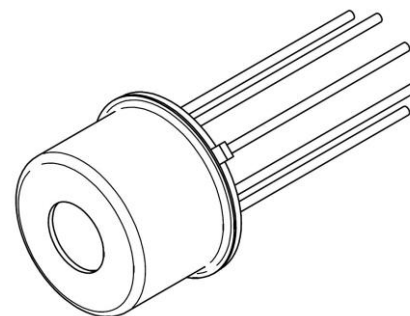

FEATURES

Spectral range: 1.7 to 5.5 μm
 III-V material
 No minimum order quantity required

APPLICATIONS

Gas detection (CO, CO₂, NO_x)
 Contactless temperature measurements

DETECTOR CONFIGURATION

Detector symbol	PVMA-5-1×1-TO39-pSiAR-70
Detector type	photovoltaic, multi-junction
Active element material	epitaxial InAsSb heterostructure
Active area, A	1 mm × 1 mm
Immersion	no
Cooling	1TE
Temperature sensor	thermistor
Detector package	TO39
Acceptance angle, Φ	~70 deg.
Window	pSiAR (planar silicon, anti-reflection coating)

SPECIFICATION ($T_{\text{amb}} = 293 \text{ K}$, $T_{\text{chip}} = 253 \text{ K}$, $V_b = 0 \text{ V}$, unless otherwise noted)

Parameter	Test conditions / remarks	Value			Unit
		Min.	Typ.	Max.	
Active element temperature, T_{chip}		-	253	-	K
Cut-on wavelength, $\lambda_{\text{cut-on}}$ (10%)	At 10% percent of peak responsivity	-	1.7	-	μm
Peak wavelength, λ_{peak}		-	4.0	-	μm
Cut-off wavelength, $\lambda_{\text{cut-off}}$ (10%)	At 10% percent of peak responsivity	-	5.5	-	μm
Detectivity, D^*	At λ_{peak} , $f = 20 \text{ kHz}$	-	8.6×10^9	-	$\text{cm} \cdot \text{Hz}^{1/2} / \text{W}$
Current responsivity, R_i	At λ_{peak}	-	0.16	-	A/W
Time constant, τ		-	40	-	ns
Resistance, R		-	4000	-	Ω

SPECIFICATION ($T_{\text{amb}} = 293 \text{ K}$, $T_{\text{chip}} = 293 \text{ K}$, $V_b = 0 \text{ V}$, unless otherwise noted)

Parameter	Test conditions / remarks	Value			Unit
		Min.	Typ.	Max.	
Active element temperature, T_{chip}		-	293	-	K
Cut-on wavelength, $\lambda_{\text{cut-on}}$ (10%)	At 10% percent of peak responsivity	-	1.7	-	μm
Peak wavelength, λ_{peak}		-	4.0	-	μm
Cut-off wavelength, $\lambda_{\text{cut-off}}$ (10%)	At 10% percent of peak responsivity	-	5.9	-	μm
Detectivity, D^*	At λ_{peak} , $f = 20 \text{ kHz}$	-	2.3×10^9	-	$\text{cm} \cdot \text{Hz}^{1/2} / \text{W}$
Current responsivity, R_i	At λ_{peak}	-	0.14	-	A/W
Time constant, τ		-	32	-	ns
Resistance, R		-	400	-	Ω

SPECTRAL RESPONSE (Typ., $T_{amb} = 293\text{ K}$)

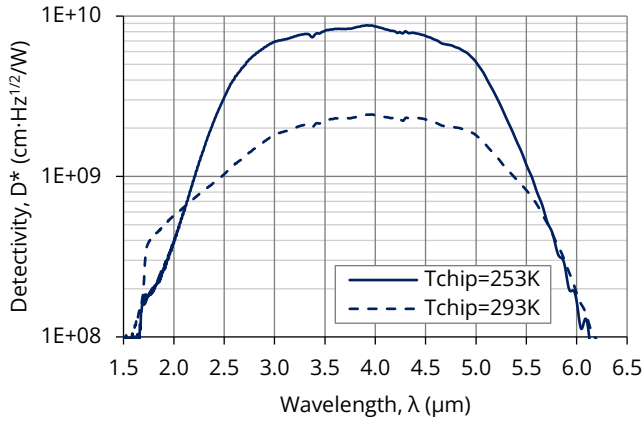

MECHANICAL LAYOUT AND PINOUT (Unit: mm)

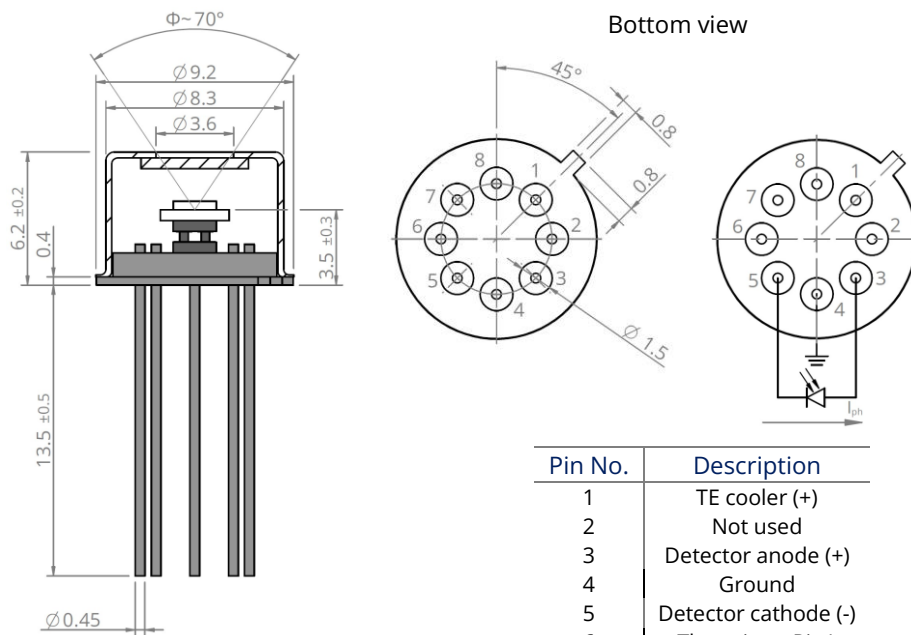

Φ - acceptance angle

Pin No.	Description
1	TE cooler (+)
2	Not used
3	Detector anode (+)
4	Ground
5	Detector cathode (-)
6	Thermistor Pin1
7	TE cooler (-)
8	Thermistor Pin 2

ABSOLUTE MAXIMUM RATINGS

Parameter	Test conditions / remarks	Value	Unit
Maximum incident optical power density	Continuous wave (CW) or single pulses $>1\ \mu\text{s}$ duration	100	W/cm^2
	Single pulses $<1\ \mu\text{s}$ duration	1	MW/cm^2
Maximum bias voltage $V_{b\text{ max}}$		-2	V
Soldering temperature	Within 5 s or less	≤ 370	$^{\circ}\text{C}$
Ambient operating temperature T_{amb}		-20 to 70	$^{\circ}\text{C}$
Storage temperature T_{stg}		-20 to 85	$^{\circ}\text{C}$
Storage humidity	No dew condensation	10 to 90	%
Maximum TE cooler current, $I_{TEC\text{ max}}$		1.67	A
Maximum TE cooler voltage, $V_{TEC\text{ max}}$		0.4	V

Stresses beyond those listed under Absolute Maximum Ratings may cause permanent damage to the device.

Constant or repeated exposure to absolute maximum rating conditions may affect the quality and reliability of the device.