

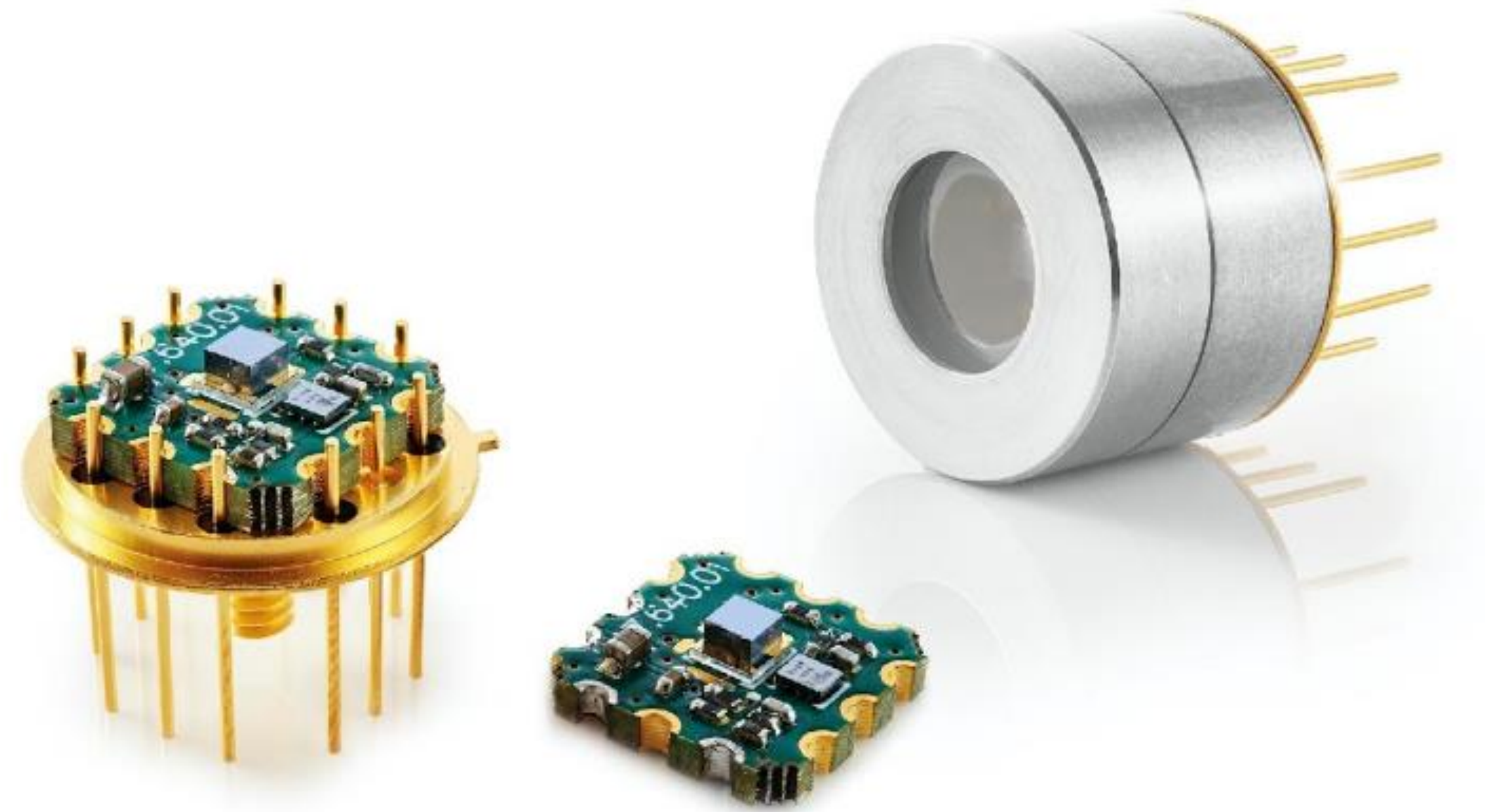

VIGO 2026 STRATEGY GROWTH TARGETS



VIGO 2026 STRATEGY GROWTH TARGETS



CHANGES ON THE INFRARED MARKET. SELECTED TRENDS

VIGO System Evolution

VIGO 2026 Vision

Potential Growth Paths

2021-2023 Financial Assumptions

DEMAND TRENDS

Infrared sharpens the senses of the Internet of Things

Internet of Things - New reality, where devices **feel, act, make decisions** and **communicate** without our intervention, transforming the manner in which societies work!

Development perspectives for Internet of Things devices market (in USD billions)

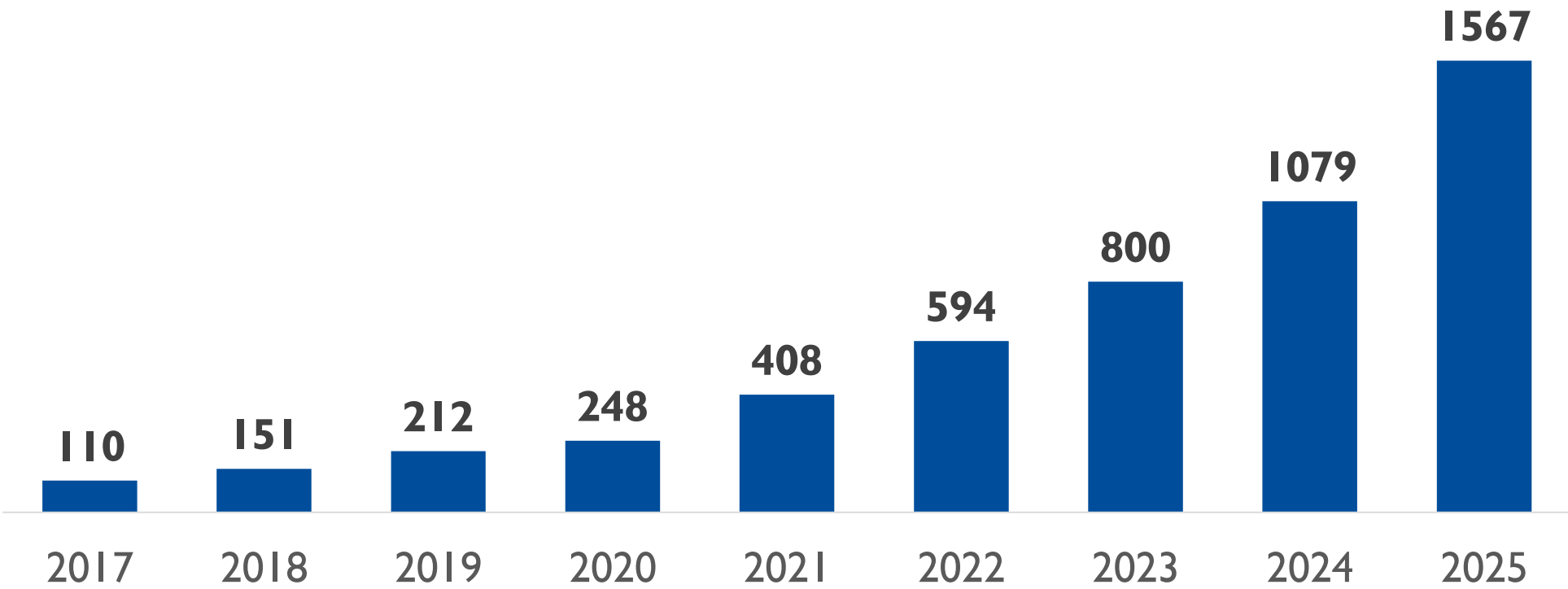

Sensors used in IoT devices (%)

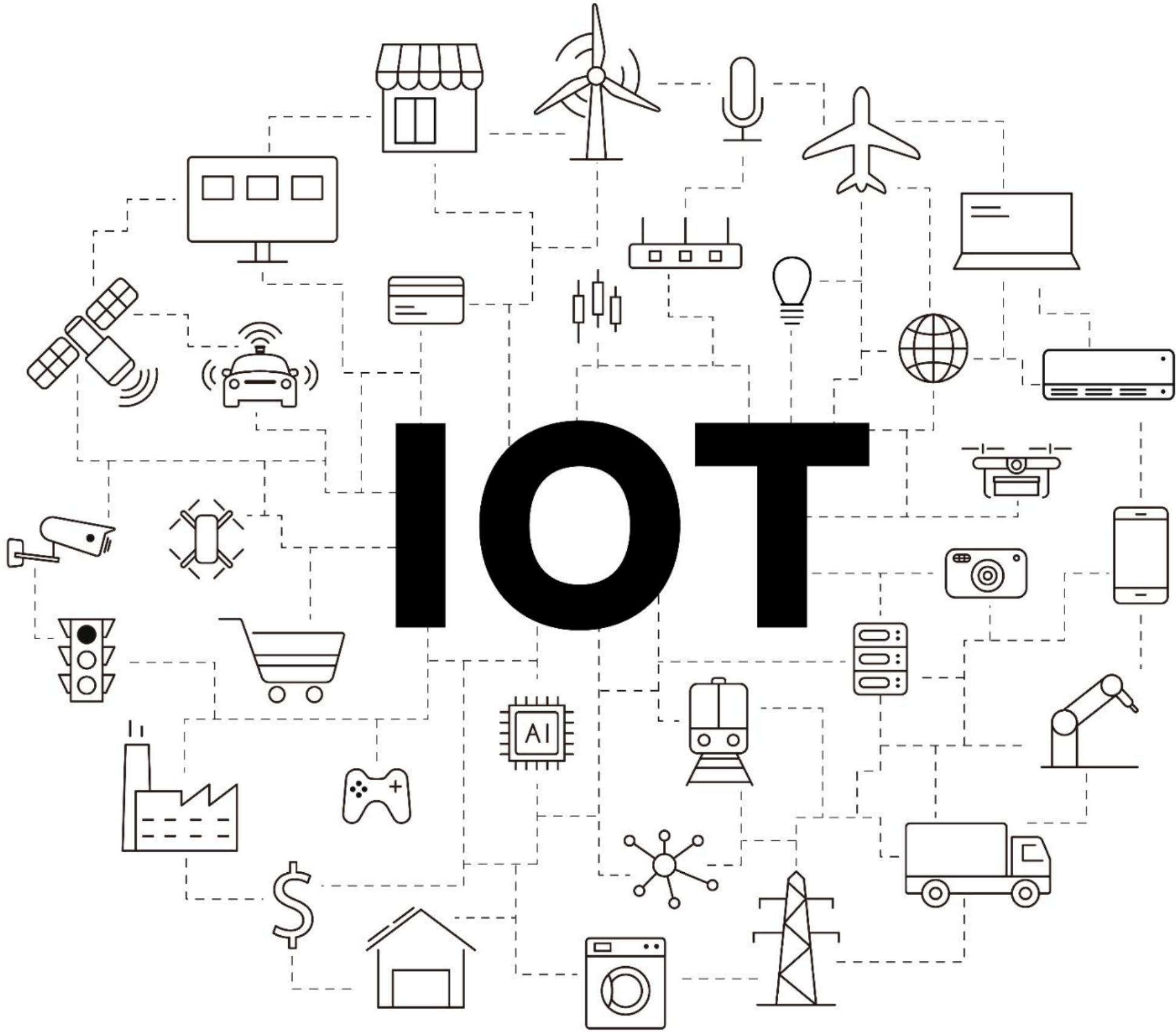
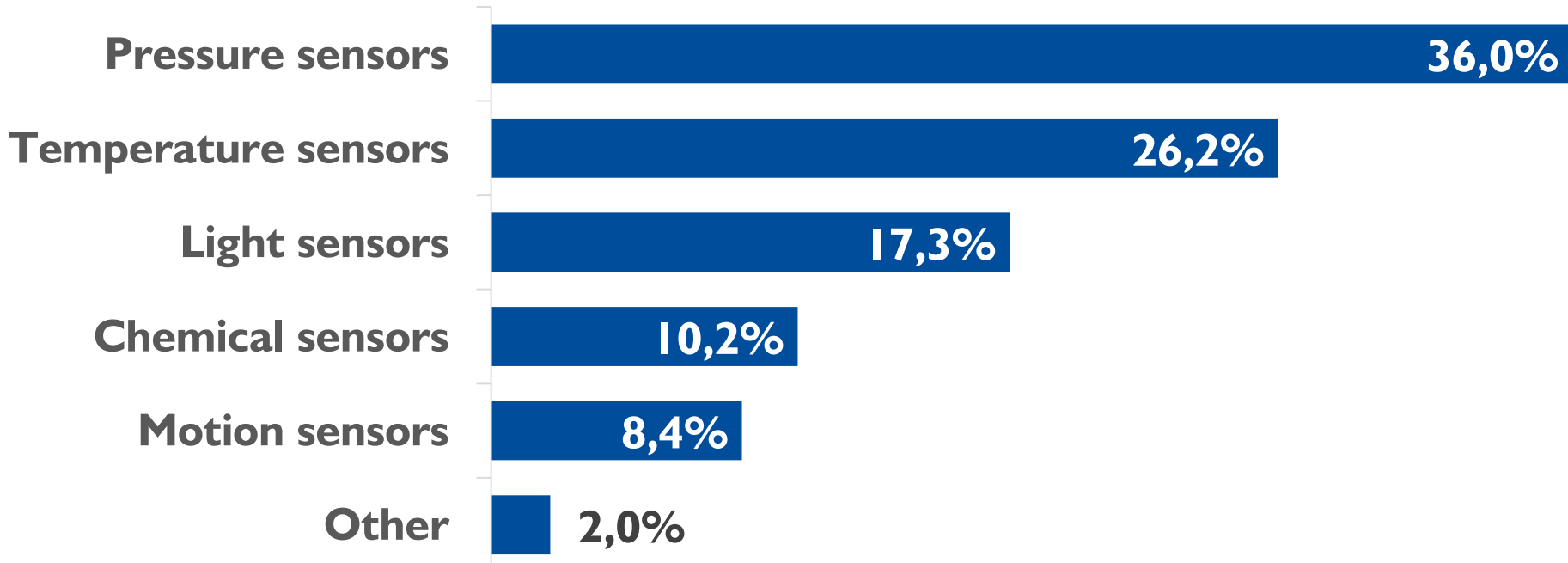

TECHNOLOGICAL TRENDS

Miniaturisation and integration is the future of infrared

Technology:

- The use of IR technology on a massive scale is possible thanks to the development of **photonic integrated circuits (PIC)**, miniaturised circuits containing a number of passive and active integrated components;
- PICs' advantages:
 - system miniaturisation,
 - low production costs for high-volume manufacturing,
 - energy efficiency,
 - lower heat emission;
- PICs are a significant link within the **Edge Computing** concept i.e. the processing of data stream from Internet of Things (IoT) devices.

Sensors used in smartphones. **Based on IR.** Other

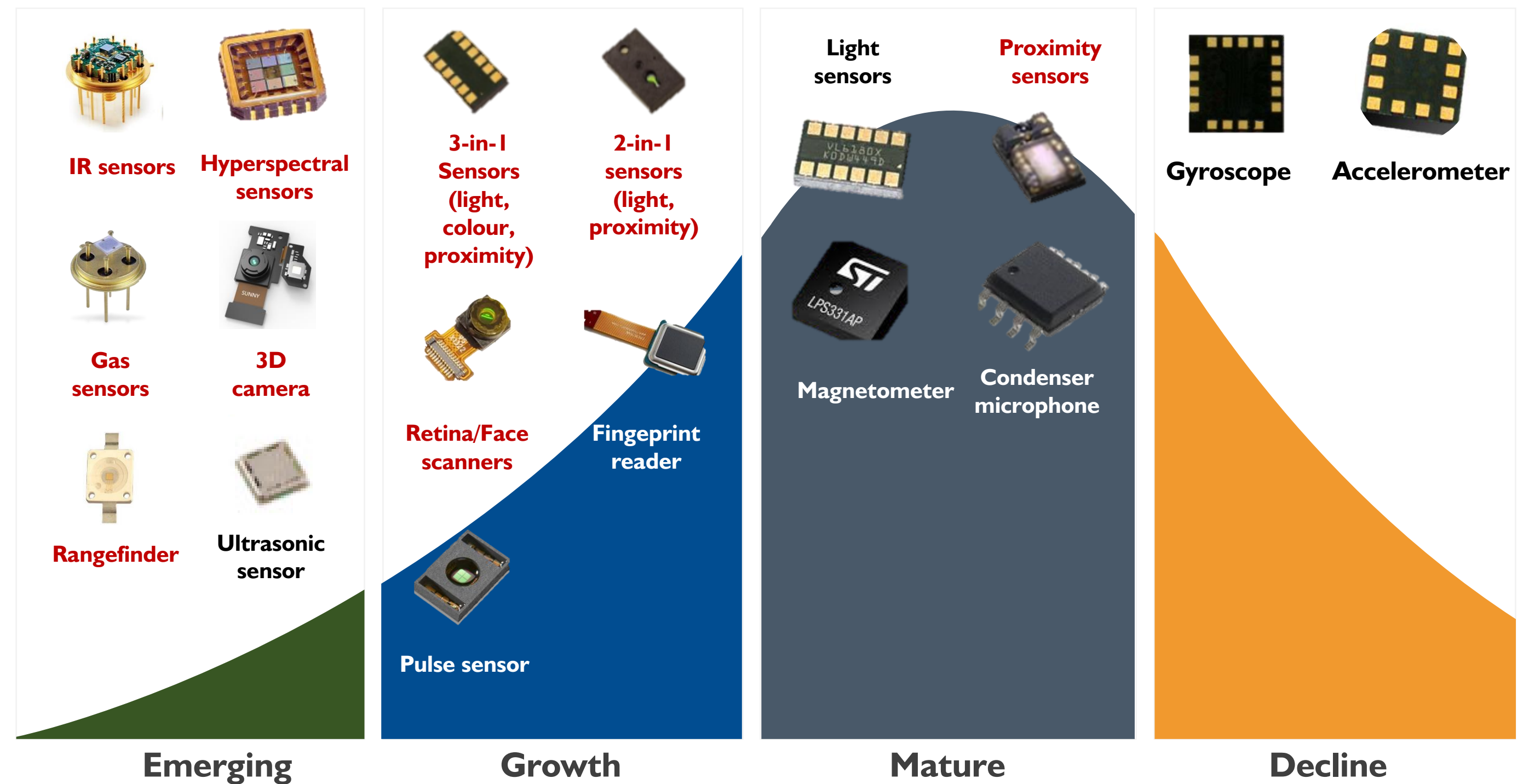

DEMAND TRENDS

Infrared as the catalyst of 'wearable lab-on-chip' development

Market

- First devices with 'lab-on-chip' based on IR will enter the market in the next 2-3 years,
- Current solutions are based on the visible spectrum and short infrared. Development of MidIR PICs will significantly boost the possibilities of the devices.

Selected players:

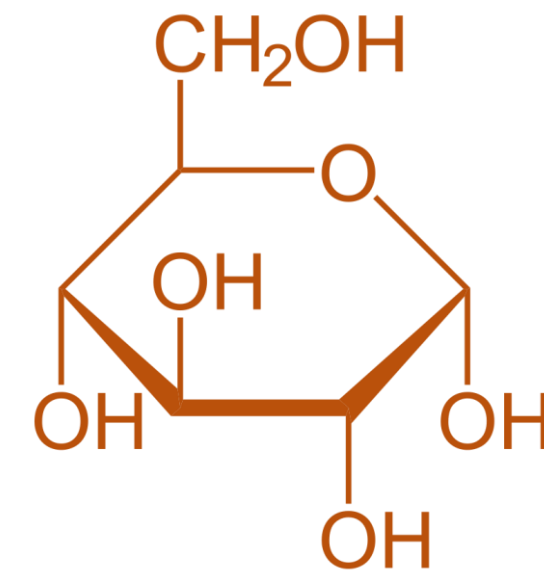

Glucose

Uses:

- Health – blood sugar level for diabetics
- Sport – metabolism
- Lifestyle – monitoring when on diet

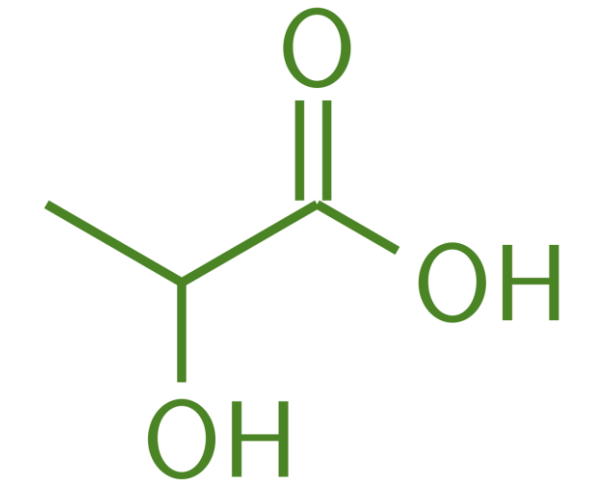

Lactic acid

Uses:

- Sport – monitoring muscle fever
- Health – disease diagnosis (e.g. sepsis)

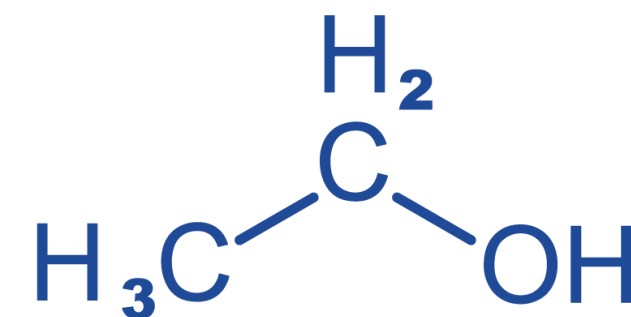

Ethanol

Uses:

- Health – monitoring the blood alcohol concentration

DEMAND TRENDS

Automotive industry bets on IR

Market

- Automobile manufacturers more and more frequently use modern solutions from the area of infrared, such as:
 - New generation LIDAR using VCSEL lasers and SPAD diodes,
 - Thermographic cameras,
 - In-cabin sensors.



Autonomous motor vehicles

Advanced driver-assistance systems ADAS

Driver monitoring systems

Gesture-based control systems

Cabin monitoring (CO2, pollution, alcohol)

Selected players:

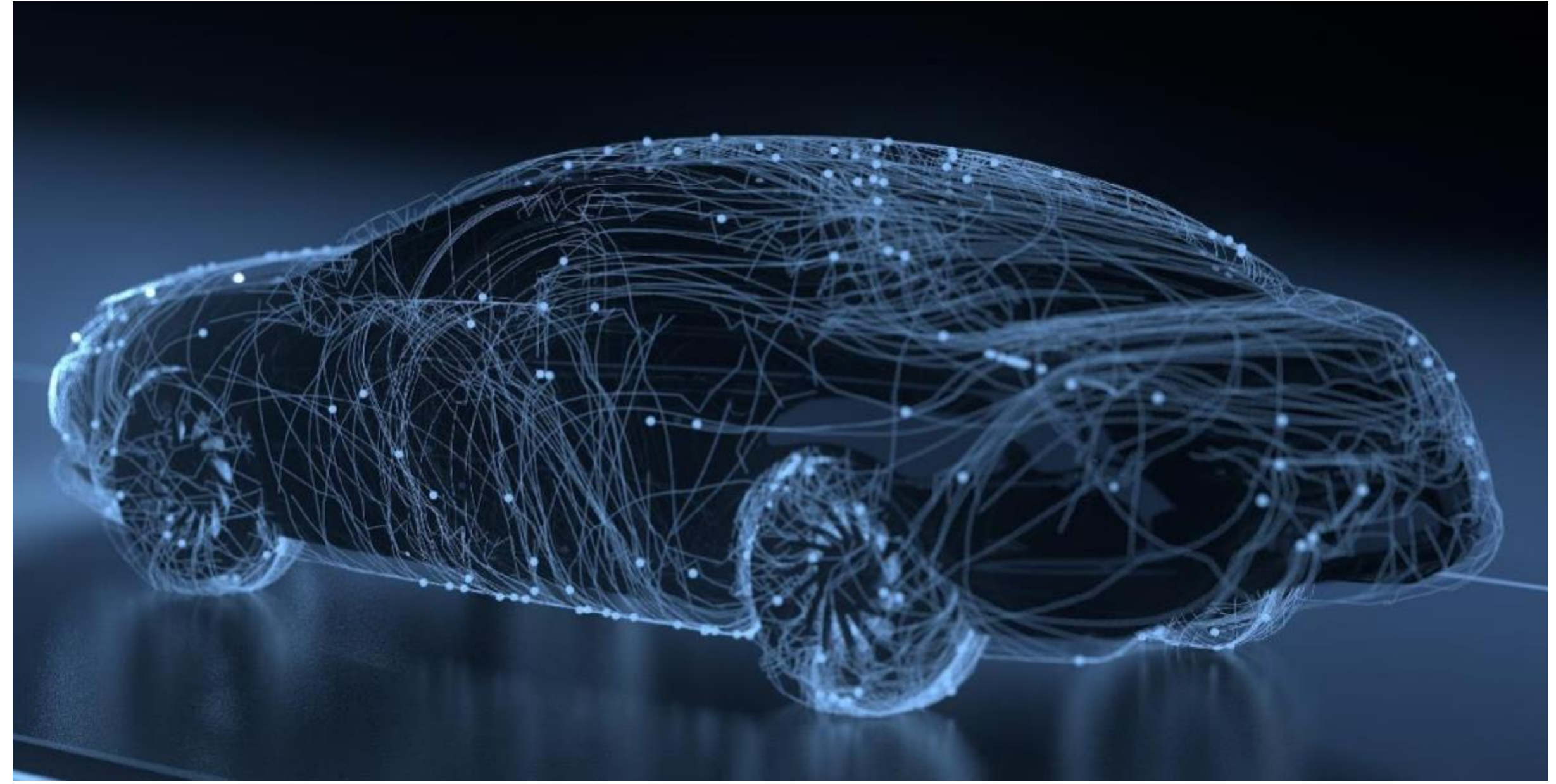



TECHNOLOGICAL TRENDS

RoHS changes the market of medium infrared

Legal conditions:

- EU Restriction of Hazardous Substances (RoHS) Directive introduced i.a. the ban to use mercury, cadmium, and lead in industrial applications after July 2024, which will considerably limit the sales market for detectors based on mercury cadmium telluride (HgCdTe) and lead selenide and sulphide (PbS, PbSe).

Perspectives:

- Legislative requirements stimulate the development of market for detectors based on semiconductor structures of A(III)B(V) group elements, which cannibalises the HgCdTe and PbS, PbSe market,
- After July 2024, the use of hazardous substances will be permitted only for military and aerospace purposes as well as for large industrial infrastructure,
- The majority of currently available detectors of III-V group have noticeably worse parameters than HgCdTe detectors. Comparable (frequently even better) parameters are offered by superlattice InAs/GaSb T2SL detectors.

ECONOMIC TRENDS

Chip market crisis kindles the growth of semiconductors industry in EU?

Circumstances:

- Deficit of integrated circuits based on silicon,
- The crisis proves the weakness of the model based on *fabless manufacturing* (chip manufacture outsourcing from specialised entities (*foundry*)), in East Asia mostly).

Perspectives:

- European countries and EU declare their intention to support the increase of chip production capacity on the Old Continent in order to double the global market share.

Structure of silicone chip global market
(the percentage of global market)

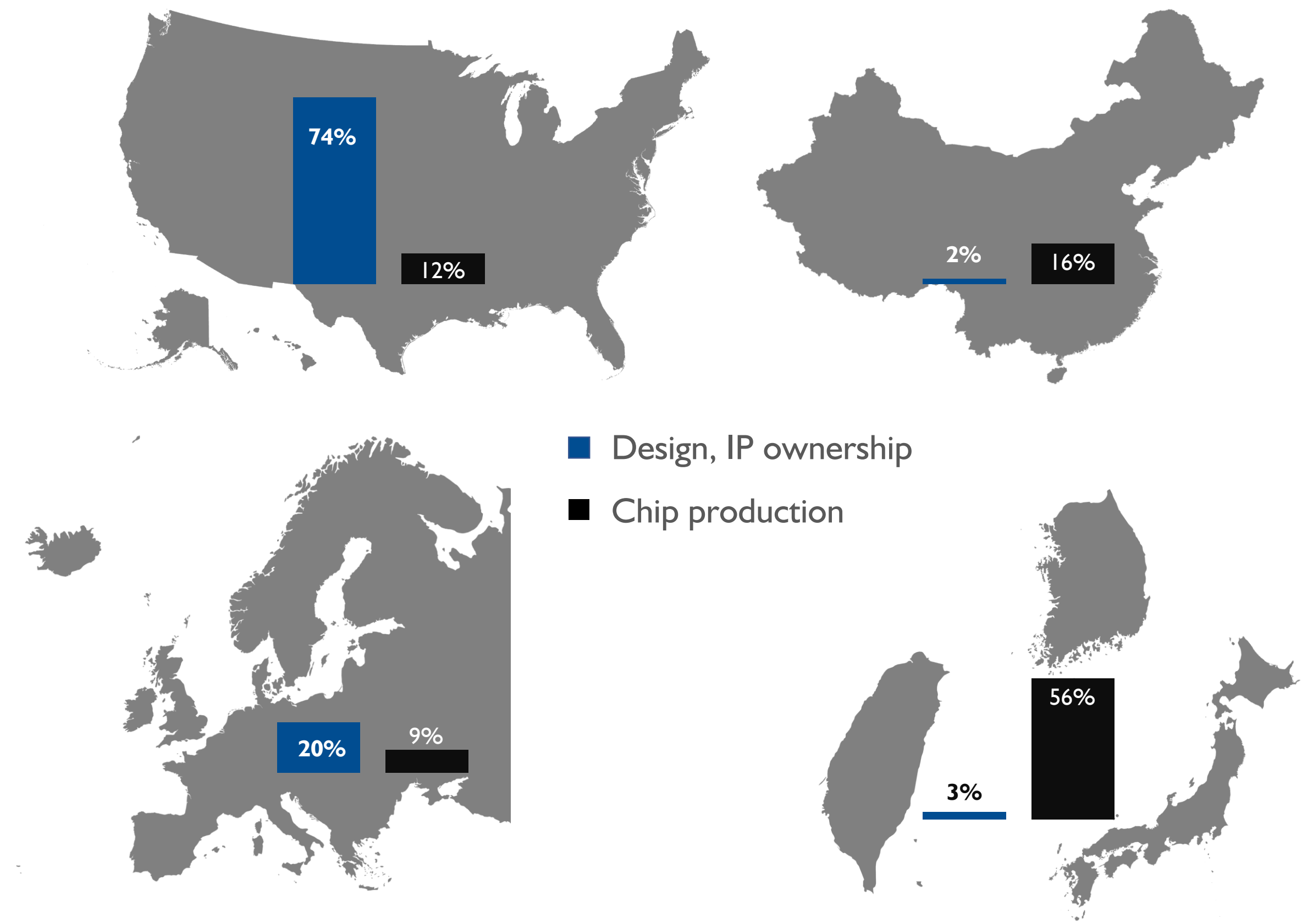

To be leaders not followers, EU industry requires urgent, ambitious action on digital technologies such as semiconductors.
Thierry Breton
 Commissioner for EU internal market

ECONOMIC TRENDS

Mergers, acquisitions and IPO in the photonic industry

Market:

- 2018-2020 marked by investment activity in the photonic industry, both M&A and IPO/SPO.

Main trends:

- Consolidation, vertical integration around market leaders,
- Strategic acquisitions aimed at strengthening market positions,
- Investments, by business investors (i.a. from automotive industry), in outstanding entities from the photonic industry (biosensors and LIDARs producers).

M&A transactions value in the photonic industry (in USD billion)

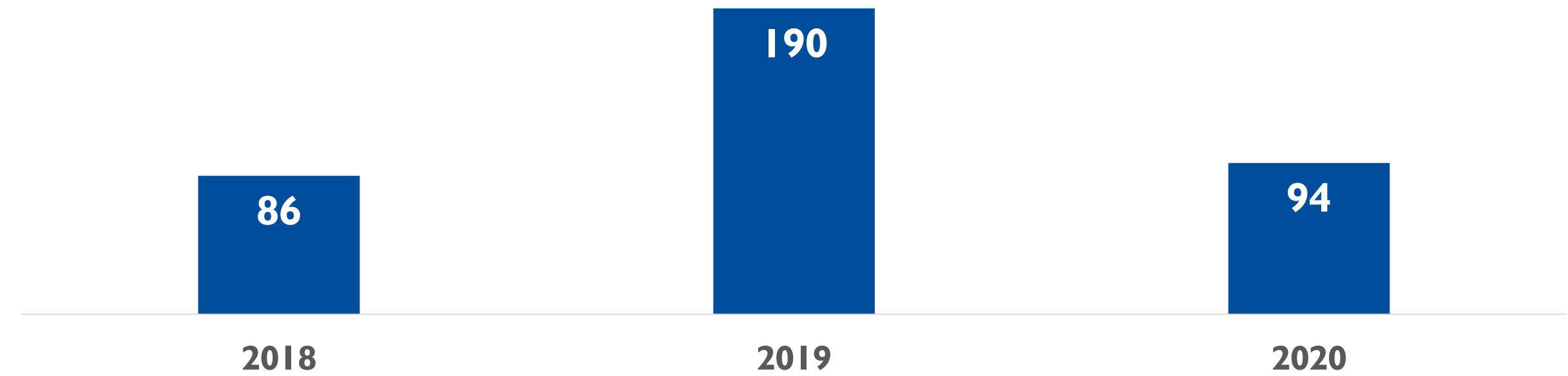

Selected transactions in the photonic industry

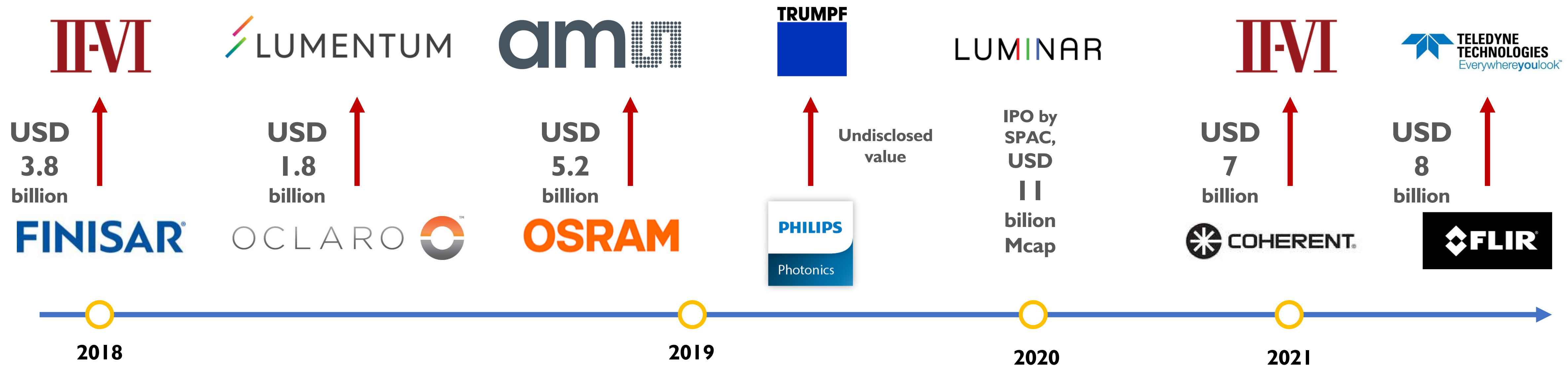

VIGO 2026 STRATEGY GROWTH TARGETS



Changes on the infrared market. Selected trends

VIGO SYSTEM EVOLUTION

VIGO 2026 Vision

Potential Growth Paths

2021-2023 Financial Assumptions

VIGO SYSTEM EVOLUTION

New products based on III-V materials

Technologies:

- Thanks to the investments in infrastructure realised in the years 2014-2020 (MBE laboratory, high-volume MOCVD in the III-V epitaxy department), VIGO System has remarkably extended its offer to include products meeting the needs resulting from market change.

InAs/InAsSb detectors

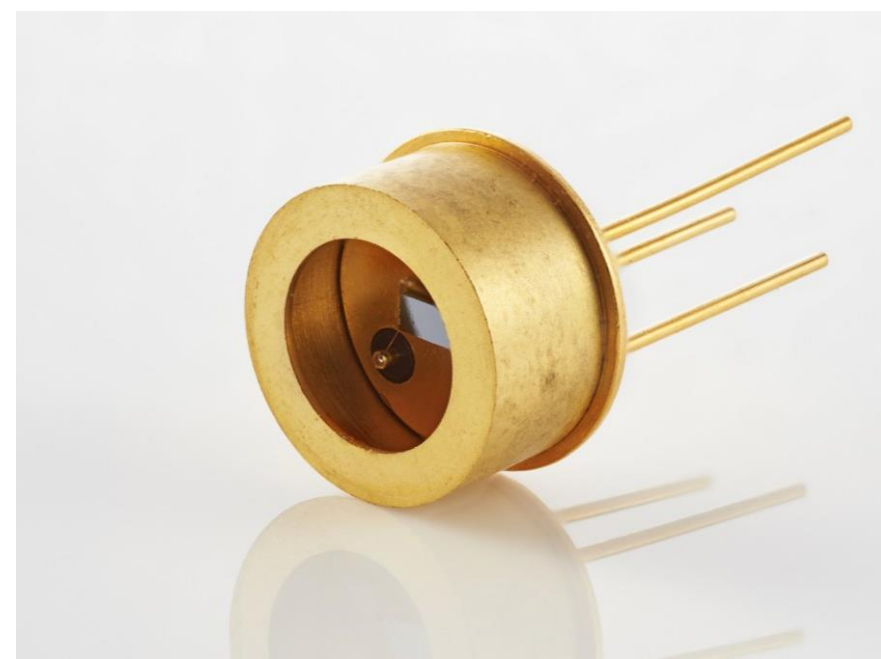

- MWIR detectors (3,4 μ m and 5 μ m) (MBE)
- Compliant with RoHS
- Detectivity comparable or better than our competitors' products

Superlattice T2SL detectors

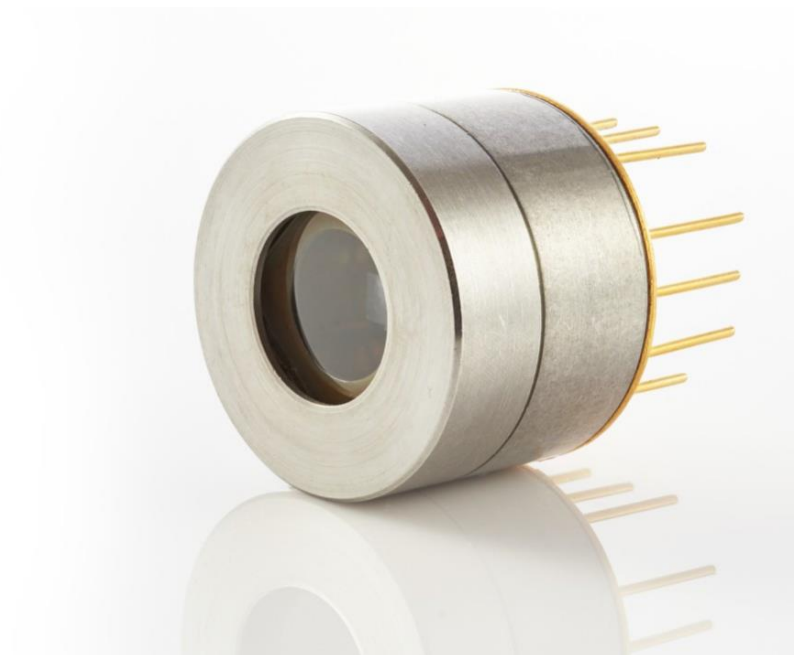

- MWIR and LWIR detectors (MBE)
- Compliant with RoHS
- Detectivity better than our competitors' products (for LWIR – significantly better)
- Parameters comparable with MCT

InGaAs detectors

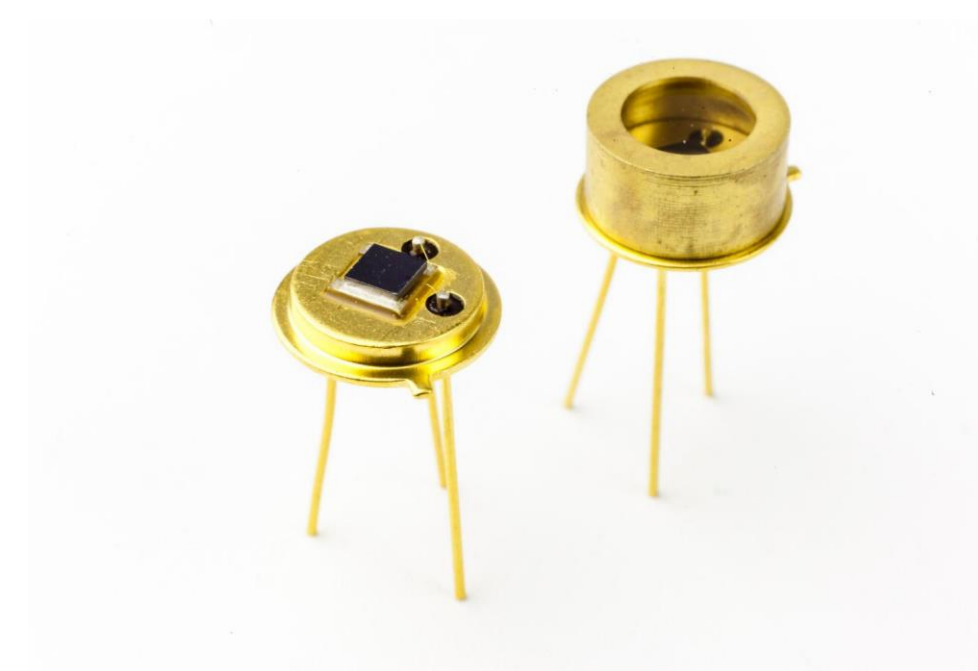

- InGaAs detectors for SWIR range (new MOCVD)
- Compliant with ROHS
- Significantly better than those available on the market
- For mass applications

III-V semiconductor materials



- Based on GaAs and InP, compliant with RoHS
- Wide range of products: surface-emitting laser, detectors, quantum dots, Bragg reflectors

VCSEL structures



- First VCSEL chips in Poland
- Mass applications (LIDARS, 3D scanning, optical communication)

Array detectors



- 8, 16, and 32-elements arrays
- Industrial and military applications

VIGO SYSTEM EVOLUTION

KEY R&D PROJECTS - MIRPIC



Politechnika
Warszawska



Aim:

- Developing the first Mid-infrared photonic integrated circuit (MIRPIC) on the market

MIRPIC research project

- Technological project carried out with Warsaw University of Technology and Institute of Microelectronics and Photonics,
- Start: April 2021.
- Duration of the project: 3 years,
- Total budget: PLN 29.3 million, Grant: PLN 26.6 million.

Potential applications

- Miniature gas sensors (smart cities, intelligent household appliances, automotive industry),
- Advanced medical equipment,
- Wearable (high end).

Gas detectors

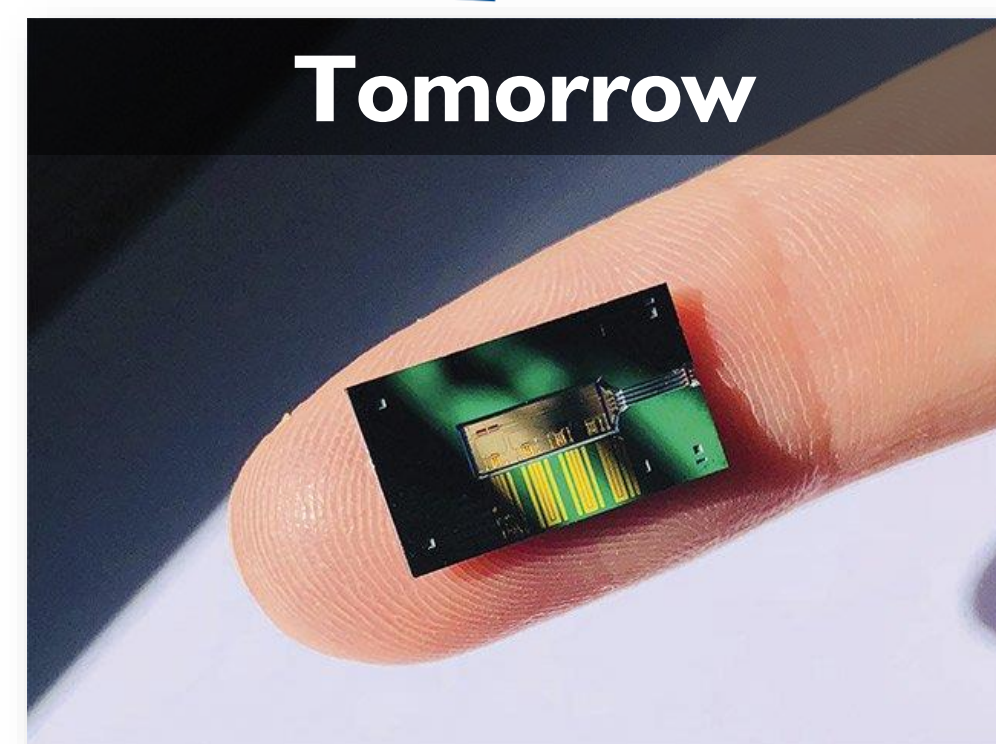
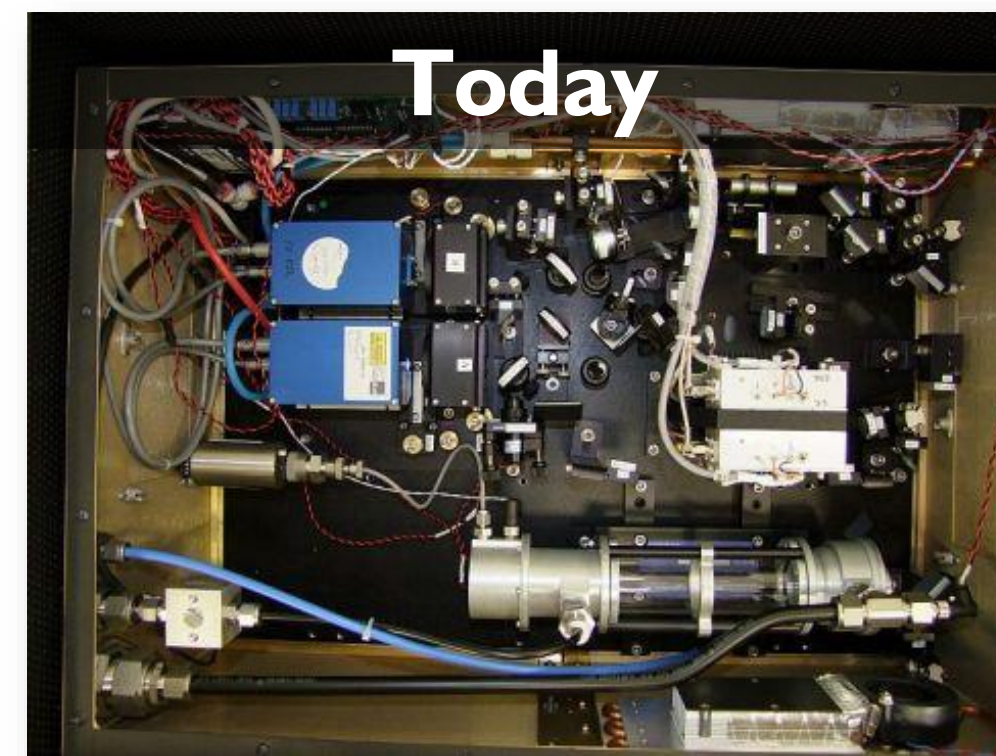

Over 10 years of experience of the new VIGO team in designing photonic integrated circuits.
Over 80 completed PIC projects

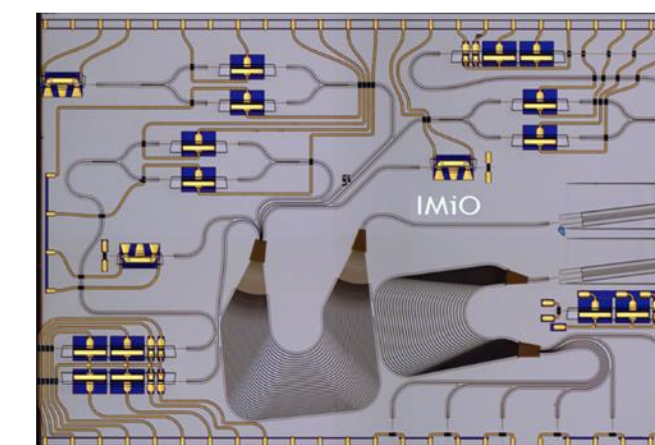

Multi-channel transceiver for free space optics

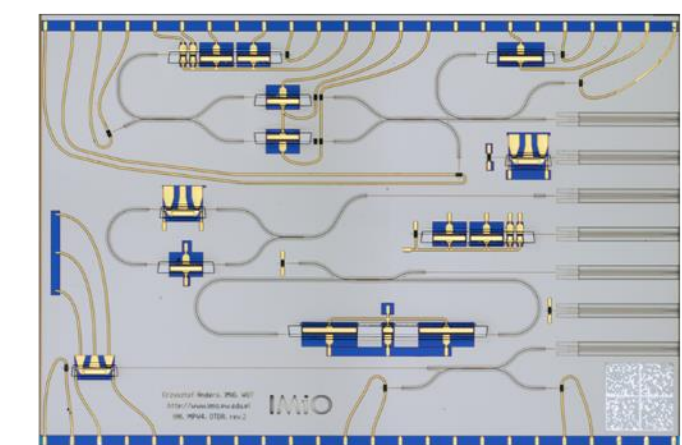

Optical time domain reflectometer



Multi-wavelength laser

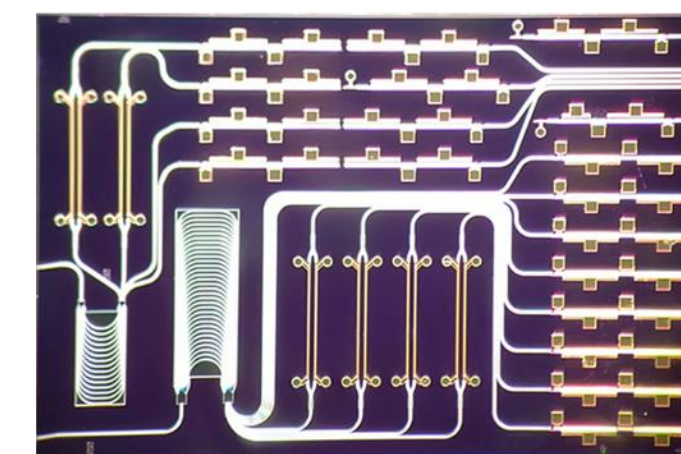

Multi-channel transmitter for FTTH networks

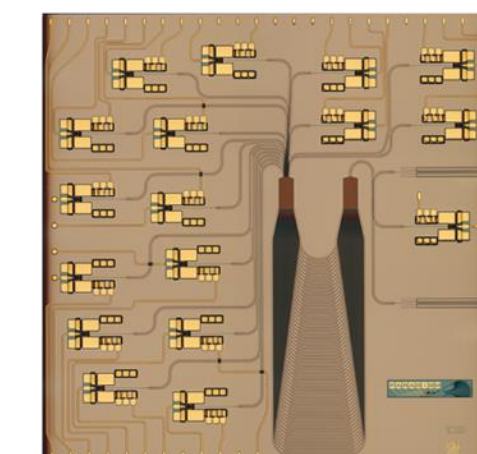

Spectrometer for FBG sensor interrogator

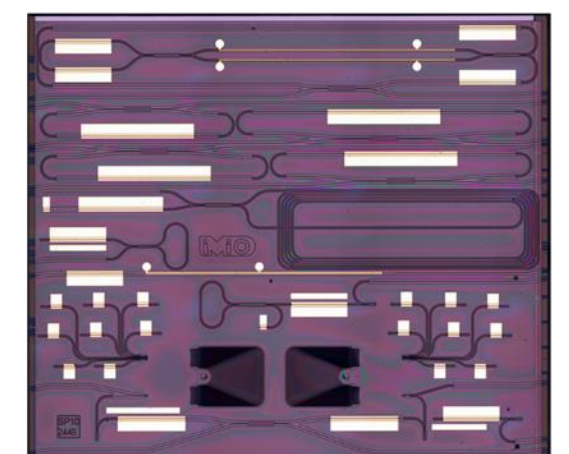

Discretely tunable laser

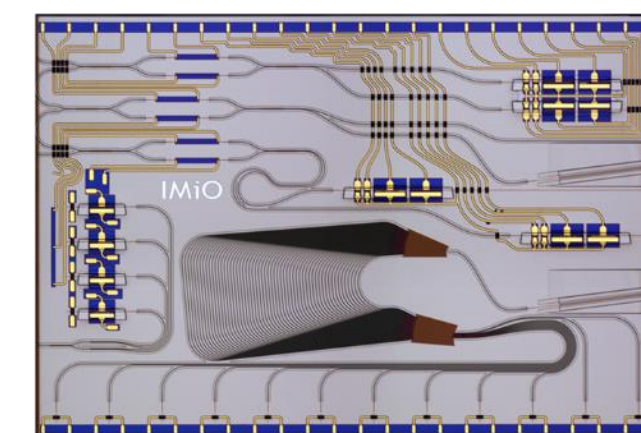

FBG interrogator unit

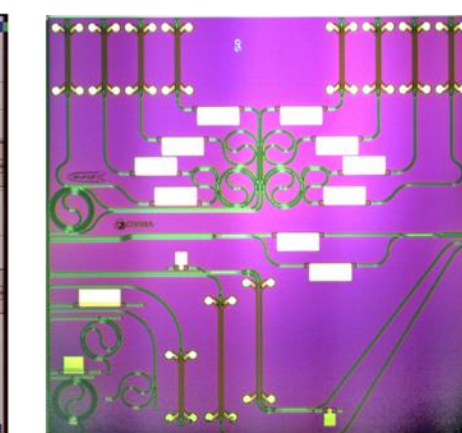

Optical time division multiplexer

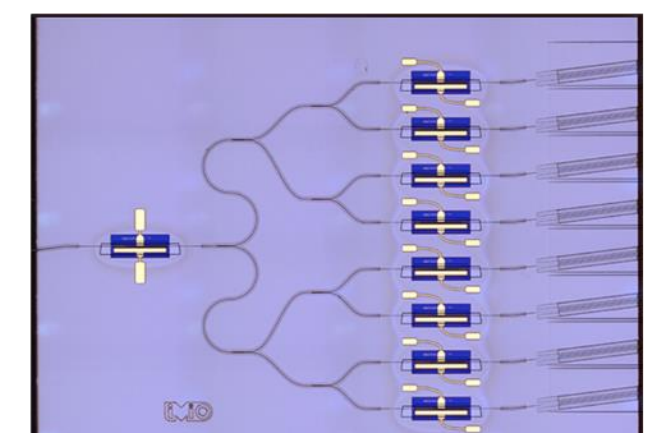

Lossless power splitter

VIGO SYSTEM EVOLUTION

KEY R&D PROJECTS - VCSEL

Aim:

- Developing a technology for production of high quality VCSEL structures as well as production and characterisation techniques for VCSEL lasers.

VCSEL research project

- Technological project carried out with Warsaw University of Technology and Łódź University of Technology,
- Start: 2019.
- Duration of the project: 3 years,
- Total budget: PLN 16.3 million, Grant: PLN 12.4 million.

Potential applications

- Automotive industry,
- Consumer electronics,
- Scanners.



**POLAND'S
FIRST VCSEL**

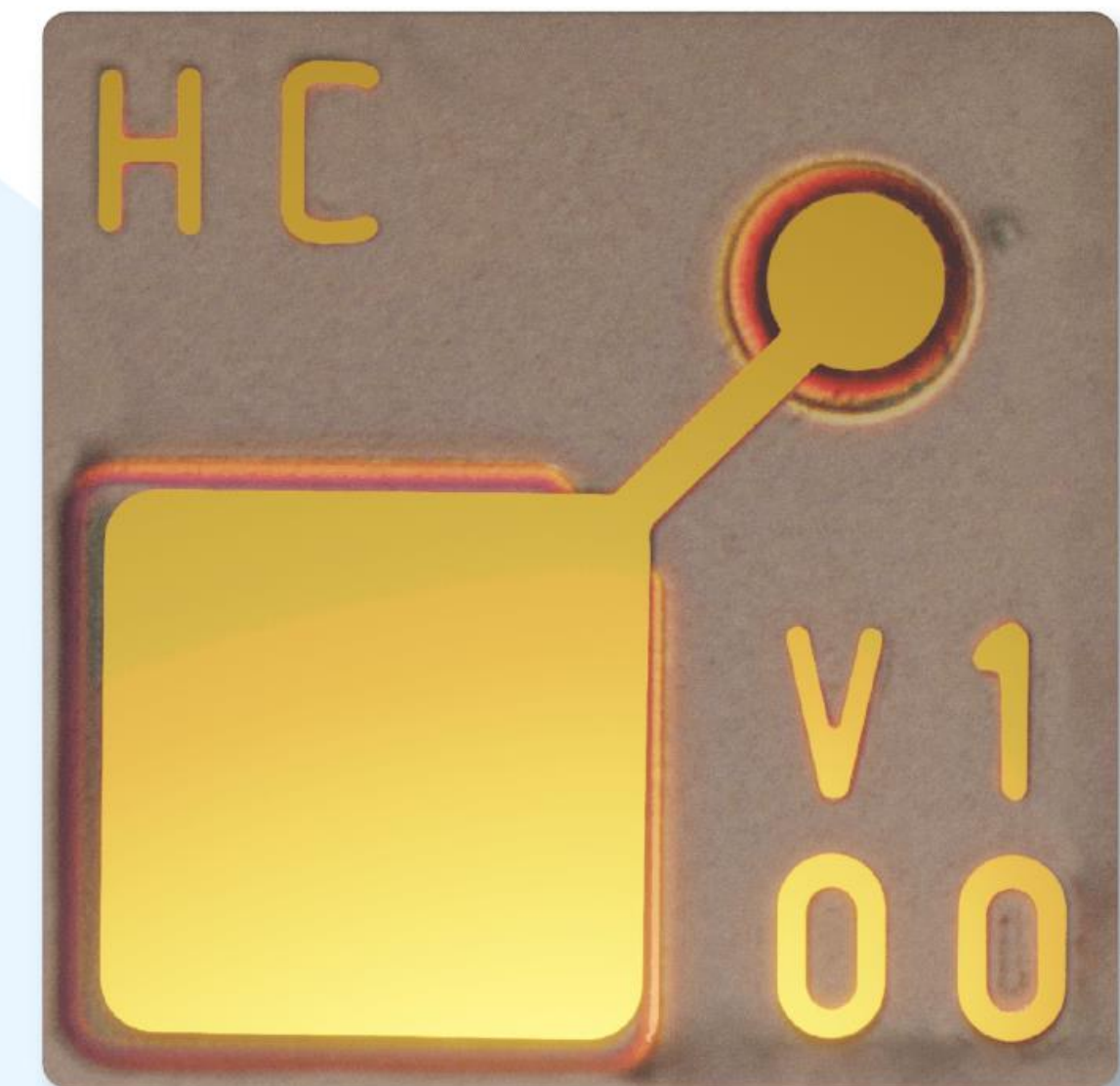

VIGO SYSTEM EVOLUTION

Opening own representative offices in key regions of the globe



Expansion directions:

- **2020** – launching VIGO Photonics Taiwan

Business assumptions: speeding up the growth on Asian markets, acquiring key accounts for the products and epitaxy services.

- **2021** – establishing VIGO Photonics USA company (planned start of the operations – 2022)

Business assumptions: speeding up VIGO's development on American market, deeper exploration of public procurement market in the USA.

Initiatives for the exploration of new application markets:

- Better research of the new mass markets for infrared sensors,
- Acquiring partners and key accounts for the development of new technologies,
- Building-up an offer for new applications.

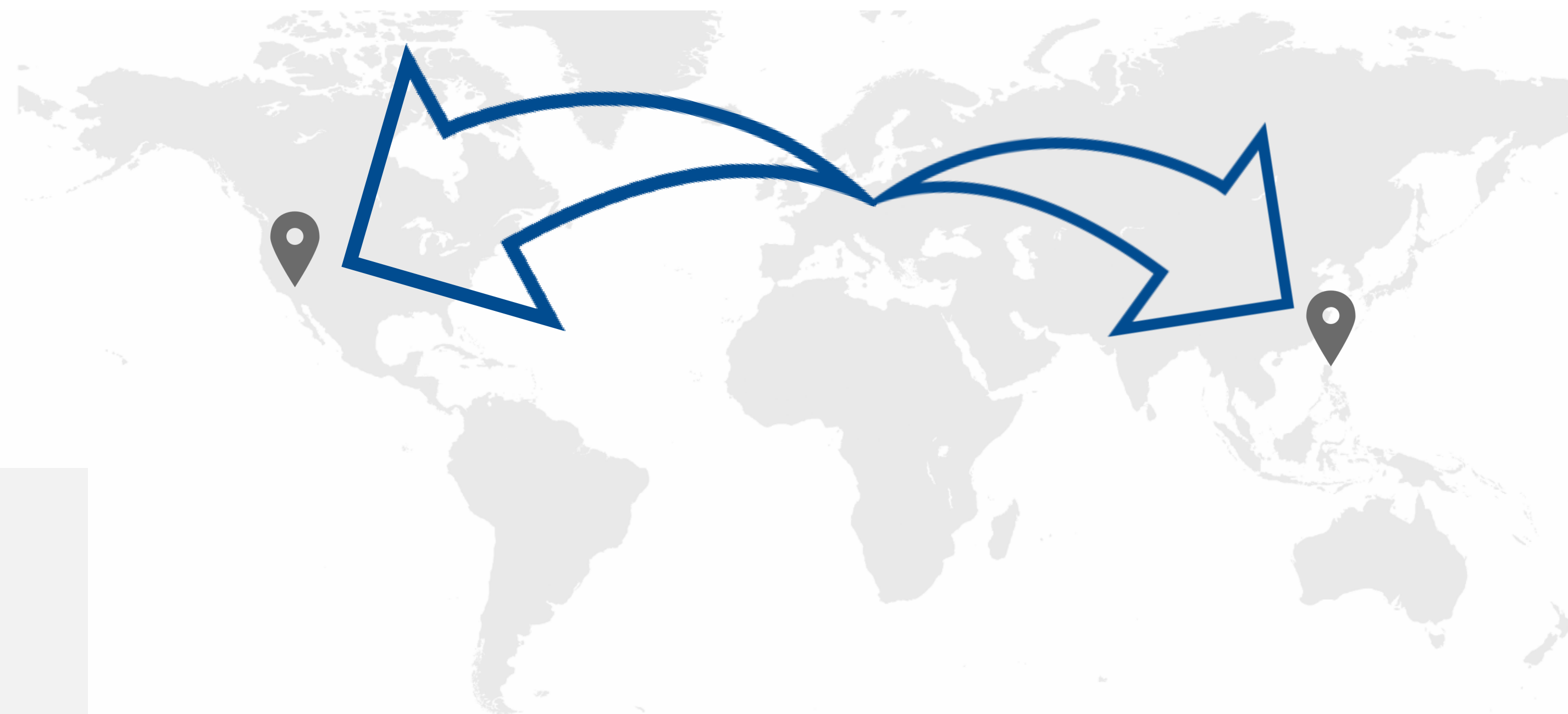

VIGO SYSTEM EVOLUTION

Automation and the increase of production capacities



Summary:

- Throughout the last 5 years, VIGO System invested **PLN 70 million** in the development of production capacity, new organisation, and processes automation, thus transforming from a manufacture of advanced detectors into a modern production plant.
- The realised investments increased the capacities manifold at all major production stages:
 - 7.5-fold increase of the lens production potential,
 - 2-fold increase of the flip-chip assembly capacity,
 - 4-fold increase of wire-bonding capacity,
 - As huge as 16-fold increase in packaging capacity,
 - 11-fold increase in encapsulation capacity.
- A great emphasis placed on work organisation and processes automation resulted in the capacity increase exceeding significantly the increase of employment in production.

Detectors production statistics (in units)

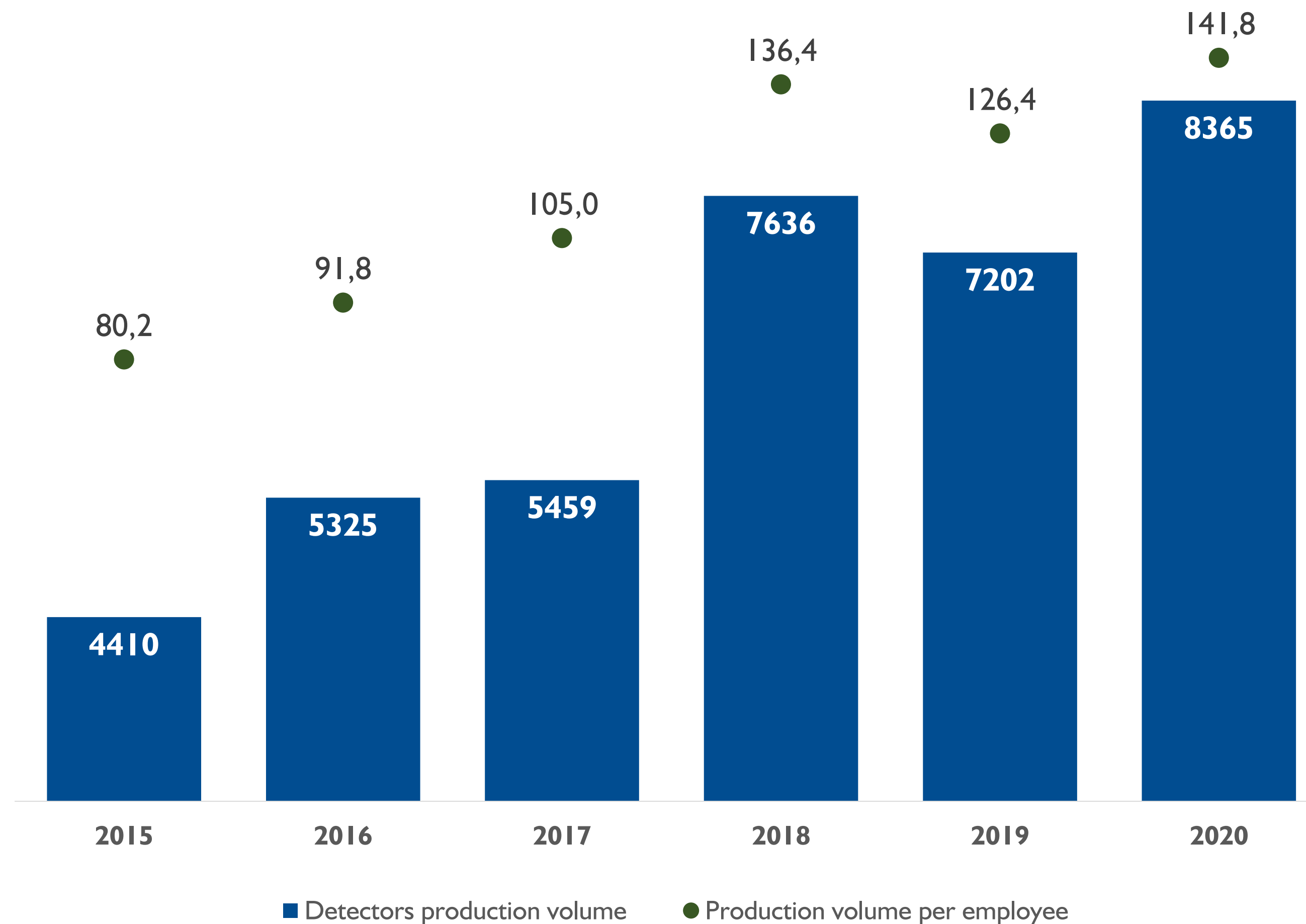

VIGO 2026 STRATEGY GROWTH TARGETS



Changes on the infrared market. Selected trends

VIGO System Evolution

VIGO 2026 Vision

Potential Growth Paths

2021-2023 Financial Assumptions



VIGO SYSTEM 2026 VISION. OUR MISSION



Sense anything. See everything

We enable the detection of any substance in any conditions

What do we do?

- We come up with ideas, conduct research, design and produce high quality complex detectors of exorbitant parameters

How do we do that?

- By listening to and understanding the needs as well as cooperating with our technological partners, we learn together with our clients

For whom do we do this?

- For pioneering technological companies, designers and system integrators searching for new solutions

What value do we bring along?

- We enable the clients to detect phenomena, acquire data, and transform it into useful information

VIGO SYSTEM 2026

Photonics Integrated Circuit Service Stack

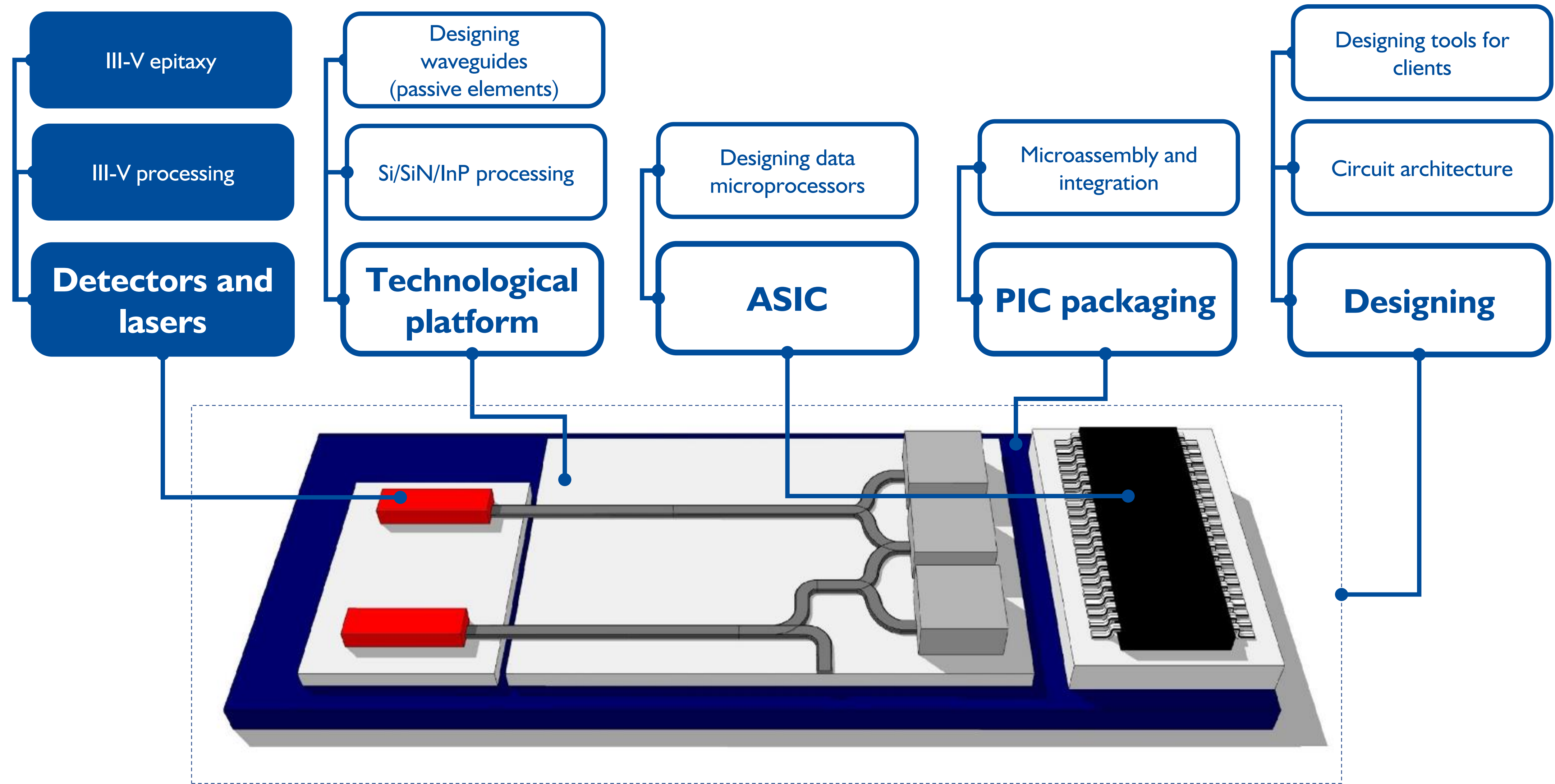

VIGO 2026 STRATEGY GROWTH TARGETS



Changes on the infrared market. Selected trends

VIGO System Evolution

VIGO 2026 Vision

POTENTIAL GROWTH PATHS

2021-2023 Financial Assumptions



POTENTIAL GROWTH PATHS

VIGO System's growth ambitions

Stage I
the development of technology for III-V detectors, radiation sources, and semiconductor materials for these applications

Stage II
entering the level of optoelectronic systems, integrated circuits, and infrared arrays

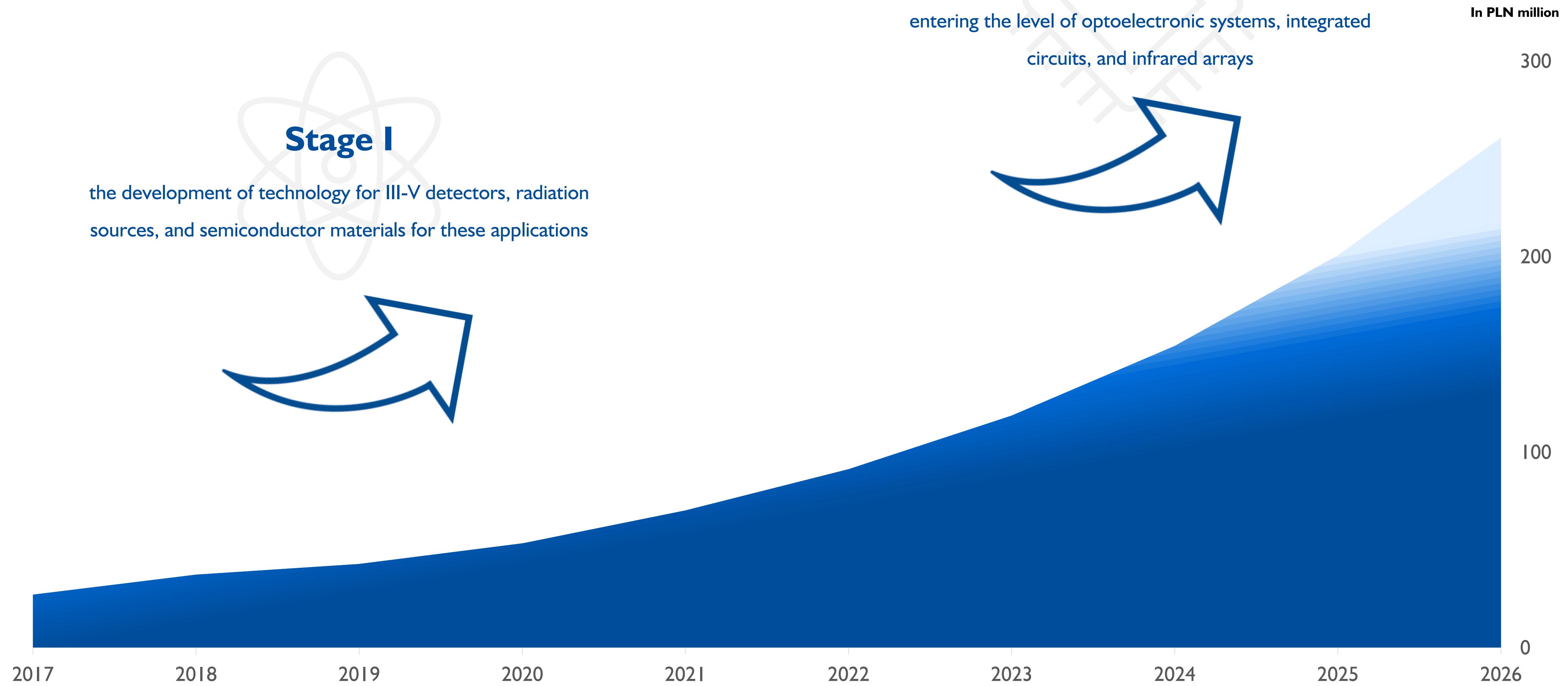

POTENTIAL GROWTH PATHS

Growth initiatives portfolio

Assumptions:

- We identify a number of business opportunities which may allow us to realize the growth ambitions by 2026.

VIGO System objectives for the years 2021-2023:

- Continuation of the commenced development projects,
- Development of bases (both technological and technical) common for key pro-growth initiatives through investments in R&D and universal infrastructure,
- Selecting, on the basis of the results of the R&D projects and the analysis of market situation, the most prospective and promising growth initiatives, and devising an investment plan needed for their implementation.

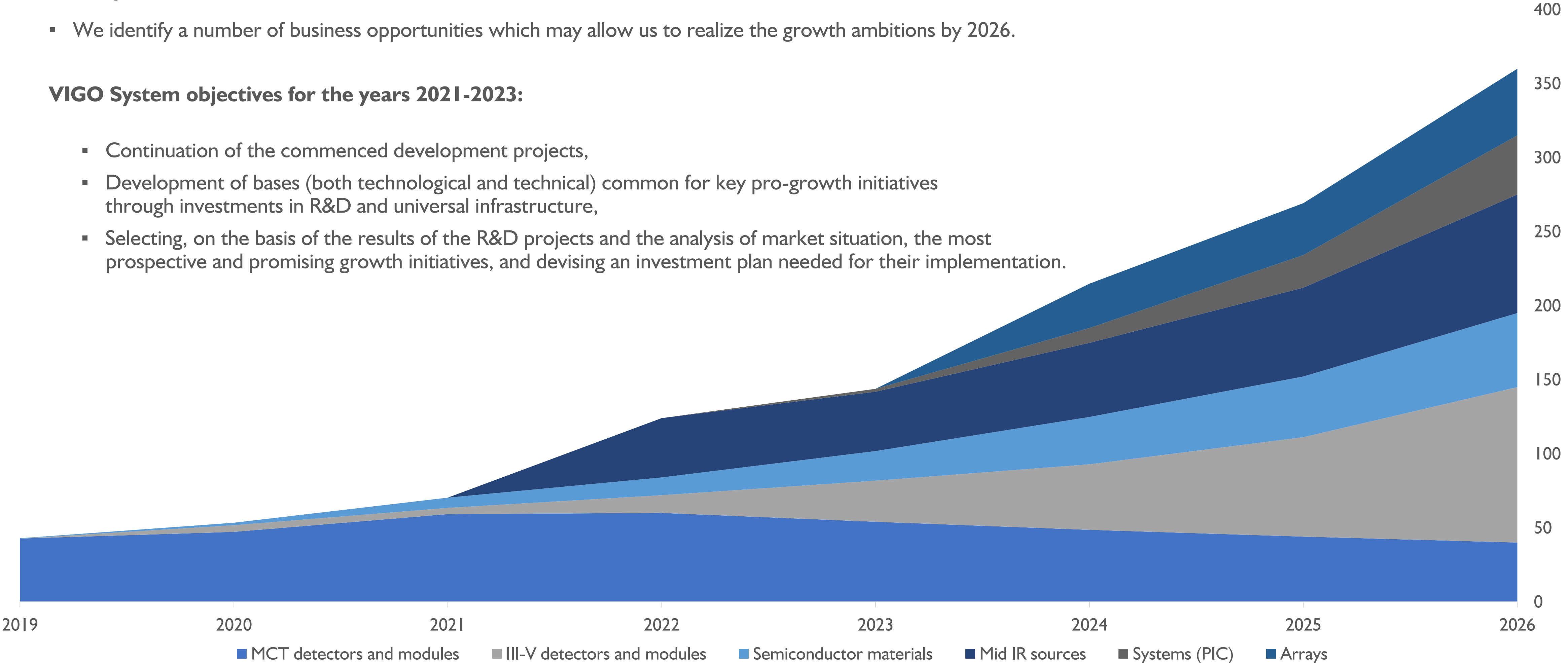

I. MCT DETECTORS INITIATIVE

Key assumptions

Determinant factors:

- Natural phasing out of the MCT market due to ROHS

Market objective:

- Exploitation of the market in the phase of its gradual disappearance by improving the customisation process and exploration of uncovered market niches,
- Expansion to the government procurement market (military, aerospace) in the USA.

Technological objective:

- Stabilisation of the multi-component detectors technology,
- Implementing digital solutions,
- Developing products for military and aerospace use.

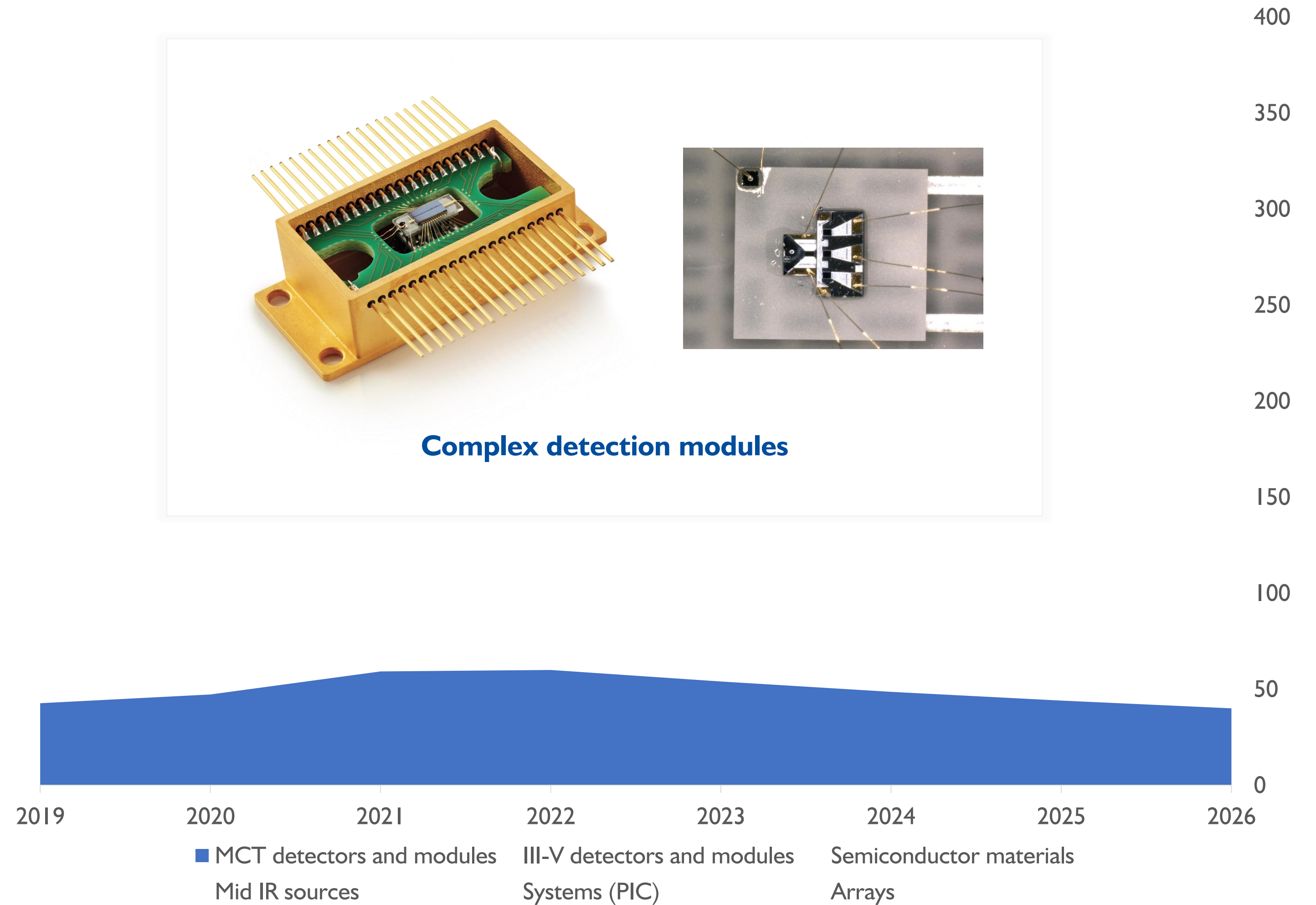
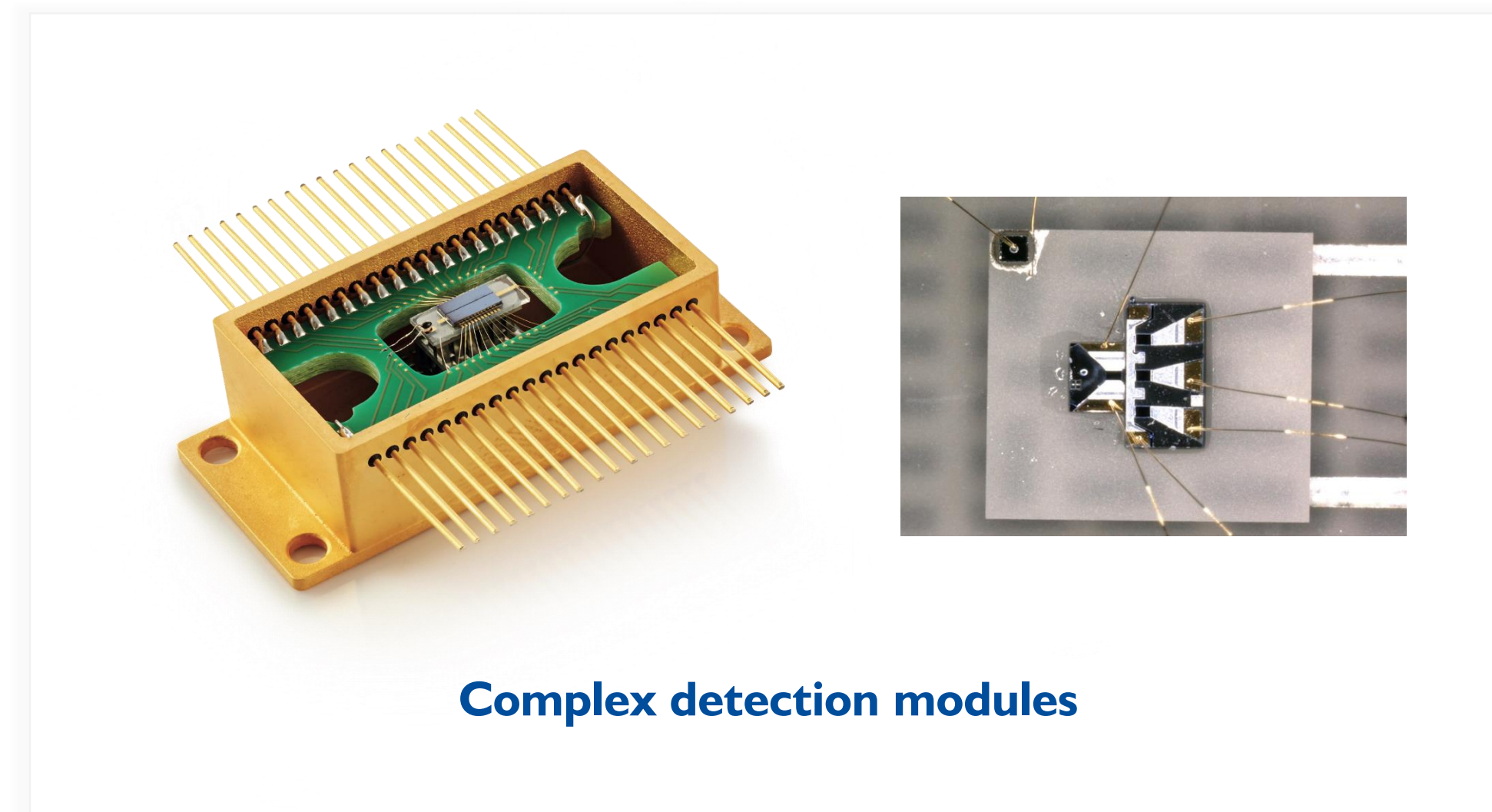

2. III-V DETECTORS AND MODULES INITIATIVE

Key assumptions

Determinant factors:

- Products compliant with RoHS
- Using megatrends related to IoT and consumer devices (measuring the level of glucose, lactic acid, alcohol),
- 3 main action models:
 - Detectors and specialised modules (continuation of the existing business model),
 - Integration of the mass produced detectors with electronics (integrated circuits),
 - Mass produced chips (large-scale optimised production > 1 million annually),
- Using synergy with new operations in the scope of III-V epitaxy (MOCVD).

Market objective:

- Becoming no. 1 on the market of III-V detectors producers within Mid-IR

Technological objective:

- Implementing superlattice T2SL technology (coming up to MCT parameters), achieving better technical parameters than our competitors in the entire Mid-IR range.

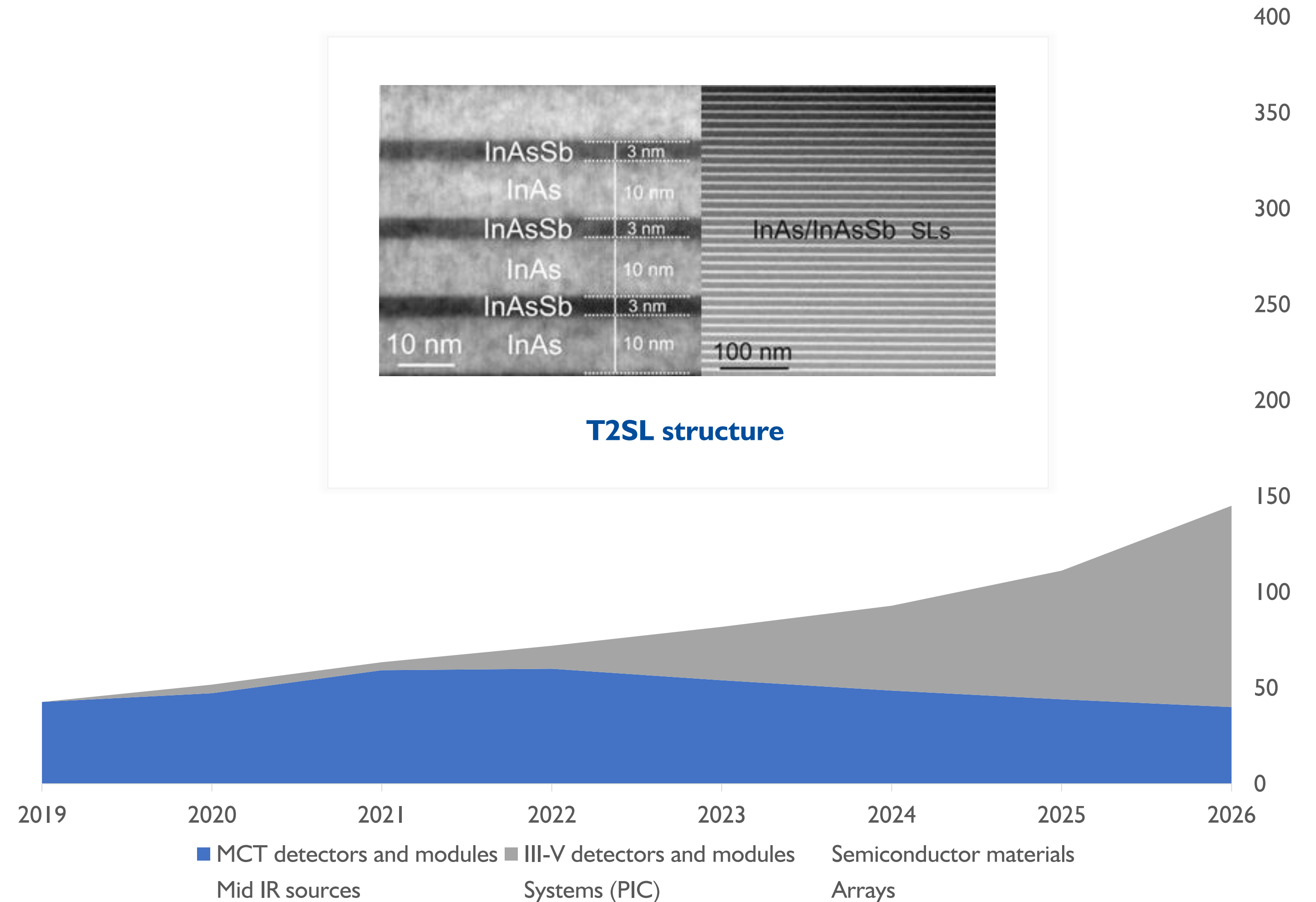
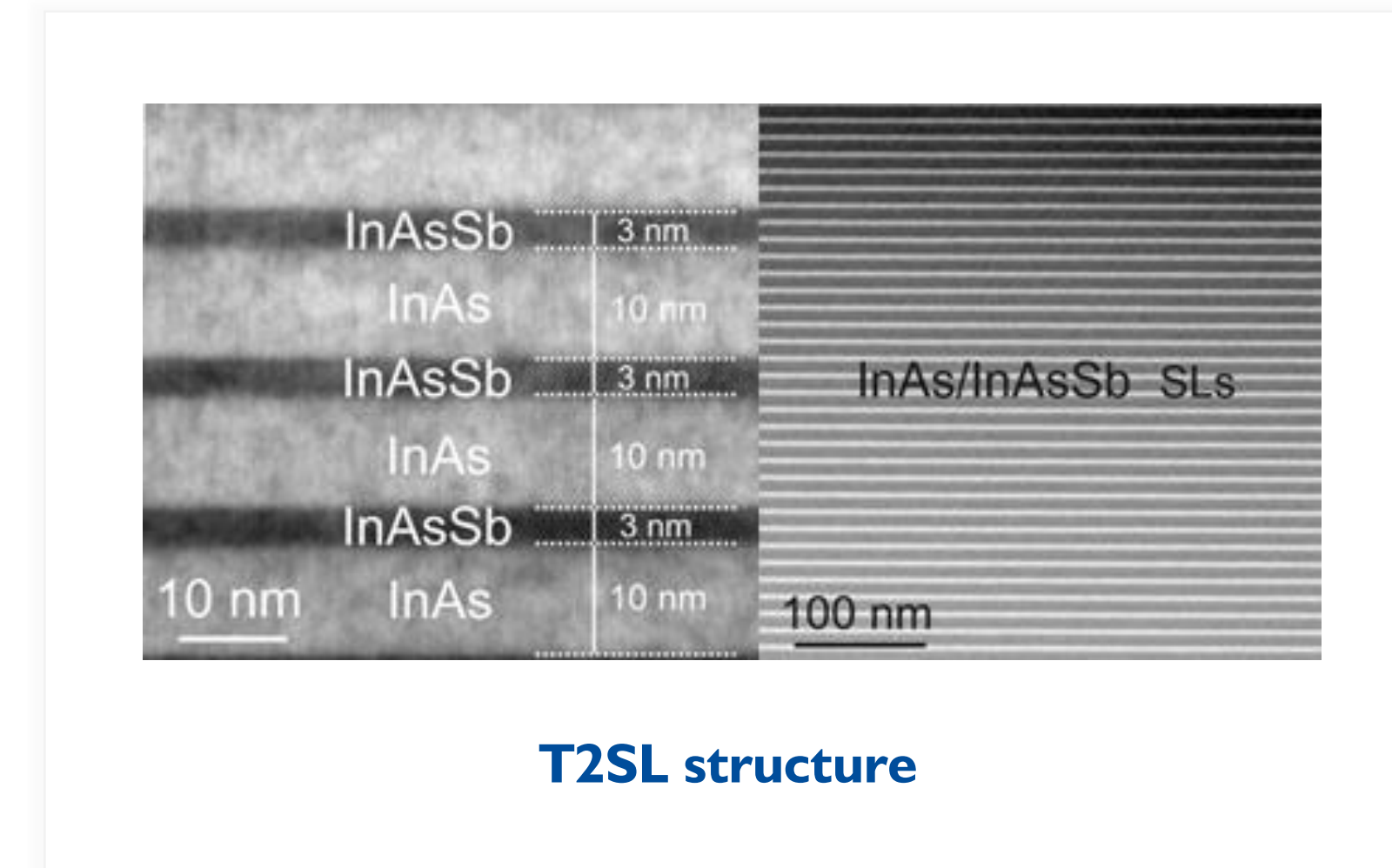

3. III-V EPITAXY AND NEAR-INFRARED SOURCES (VCSEL) INITIATIVE

Key assumptions

Determinant factors:

- Foundation of entire future operation
- Access to consumer markets, where our production capacity is insufficient
- Potential technological springboard for future growth

Market objective – Gaining visibility on the epitaxy services market, exploration of market niches (new VCSELS, innovative solutions).

Technological objective – Elaborating VCSELS production and characterisation technology.

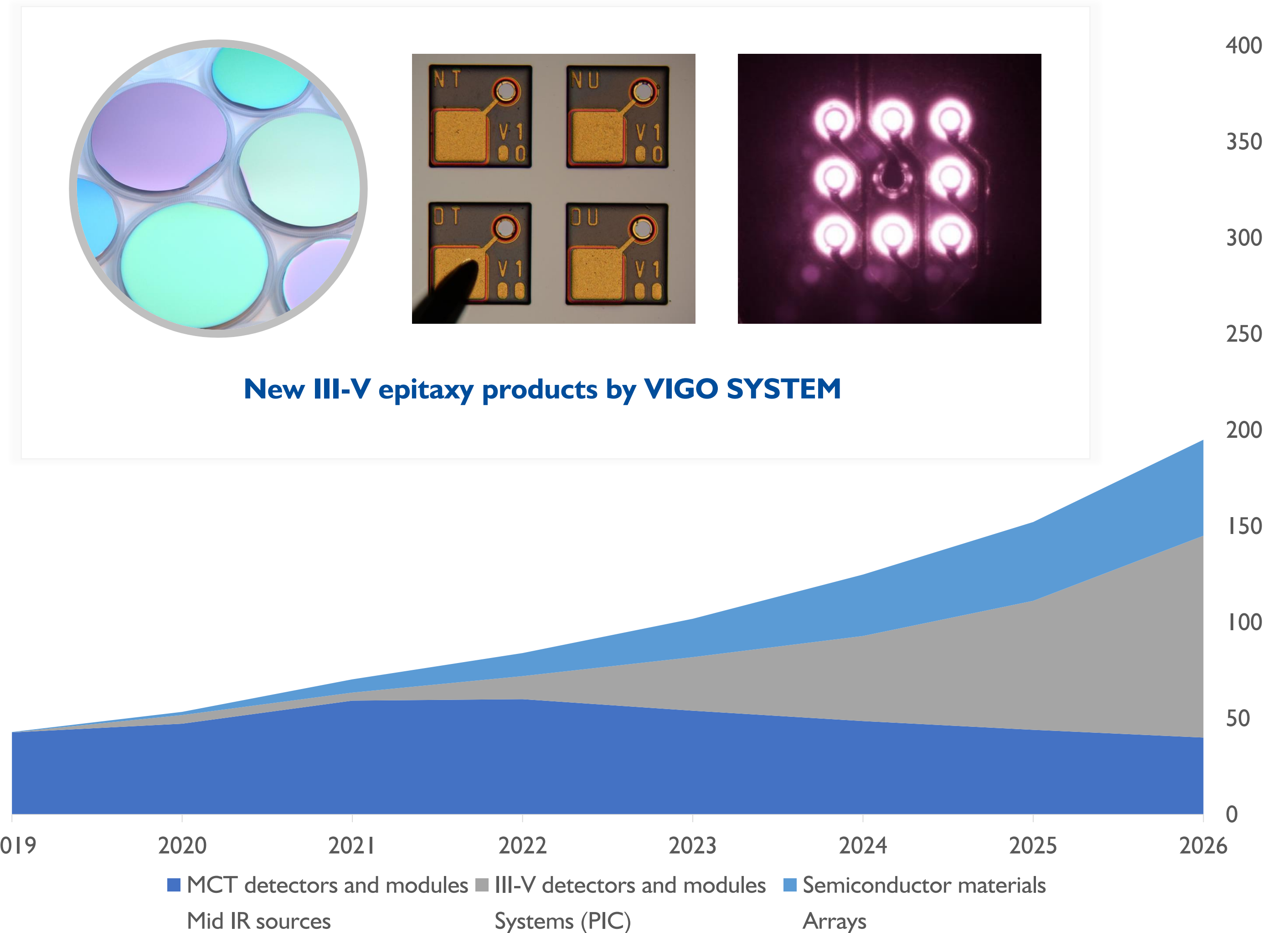

4. MID-INFRARED SOURCES (ICL, QCL, MIRLED) INITIATIVE

Key assumptions

Determinant factors:

- Securing the availability of complementary components is the prerequisite for pursuing the long-term strategy,
- Possible rapid growth through M&A and a vast synergy potential,
- Alternative scenario – developing own technology (demonstrated in-house laser structures, available patent licences for manufacturing the lasers, technological abilities at Warsaw institute).

Market objective – Strengthening the position on infrared market, entering the Mid-infrared sources market.

Technological objective – Acquiring ICL, QCL, Mir LED technologies.

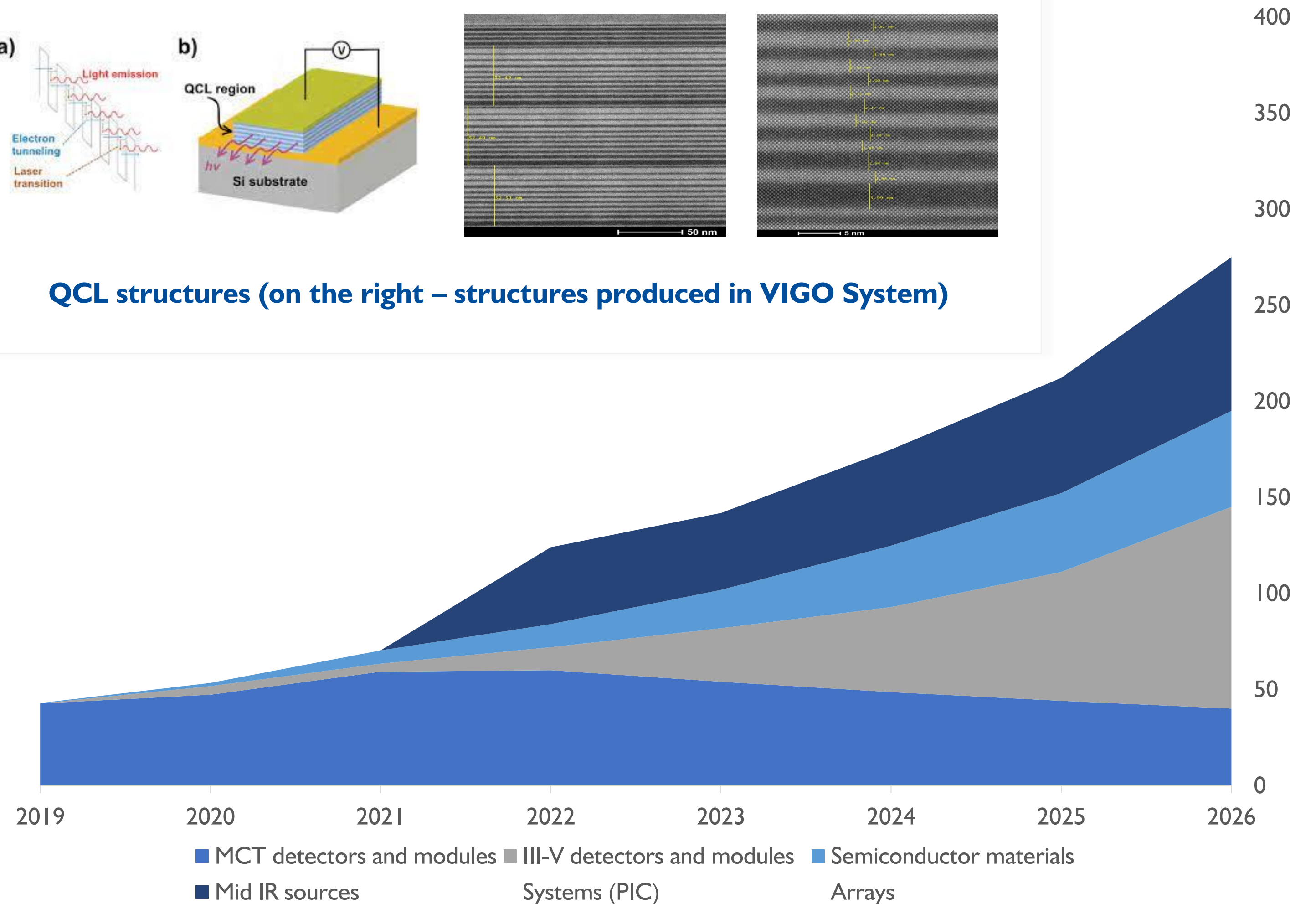
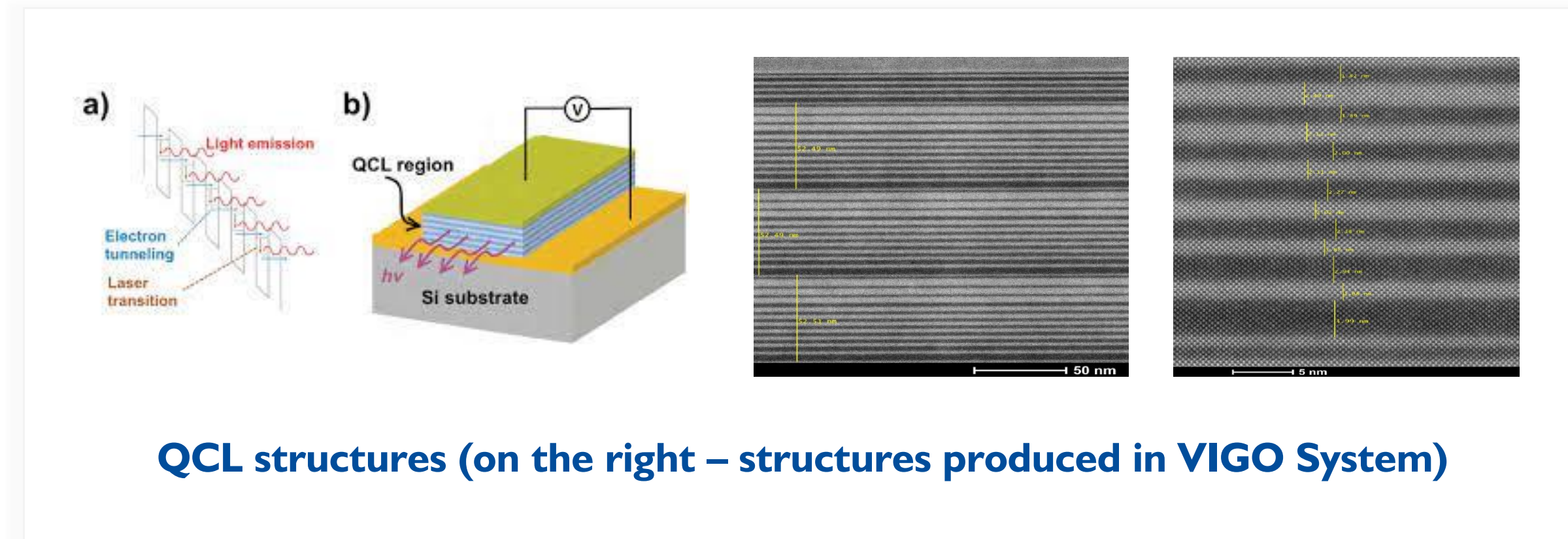

5. OPTOELECTRONIC SYSTEMS AND INTEGRATED CIRCUITS (PIC) INITIATIVE

Key assumptions

Determinant factors:

- Going up the value stream – developing ready sensory systems integrable with commonly used devices,
- The development leverage are the photonic integrated circuits (PIC) – miniaturised circuits of passive and active components on one chip.

Market objective:

- Gaining a leading position on PIC for Mid-infrared (MWIR) market,
- Acquiring a significant share in PIC for Mid-infrared (SWIR) market.

Technological objective:

- Introducing, as the first producer in the world, integrated circuits for Mid-infrared,
- Developing a flexible technological platform for a wide spectrum of applications in infrared.

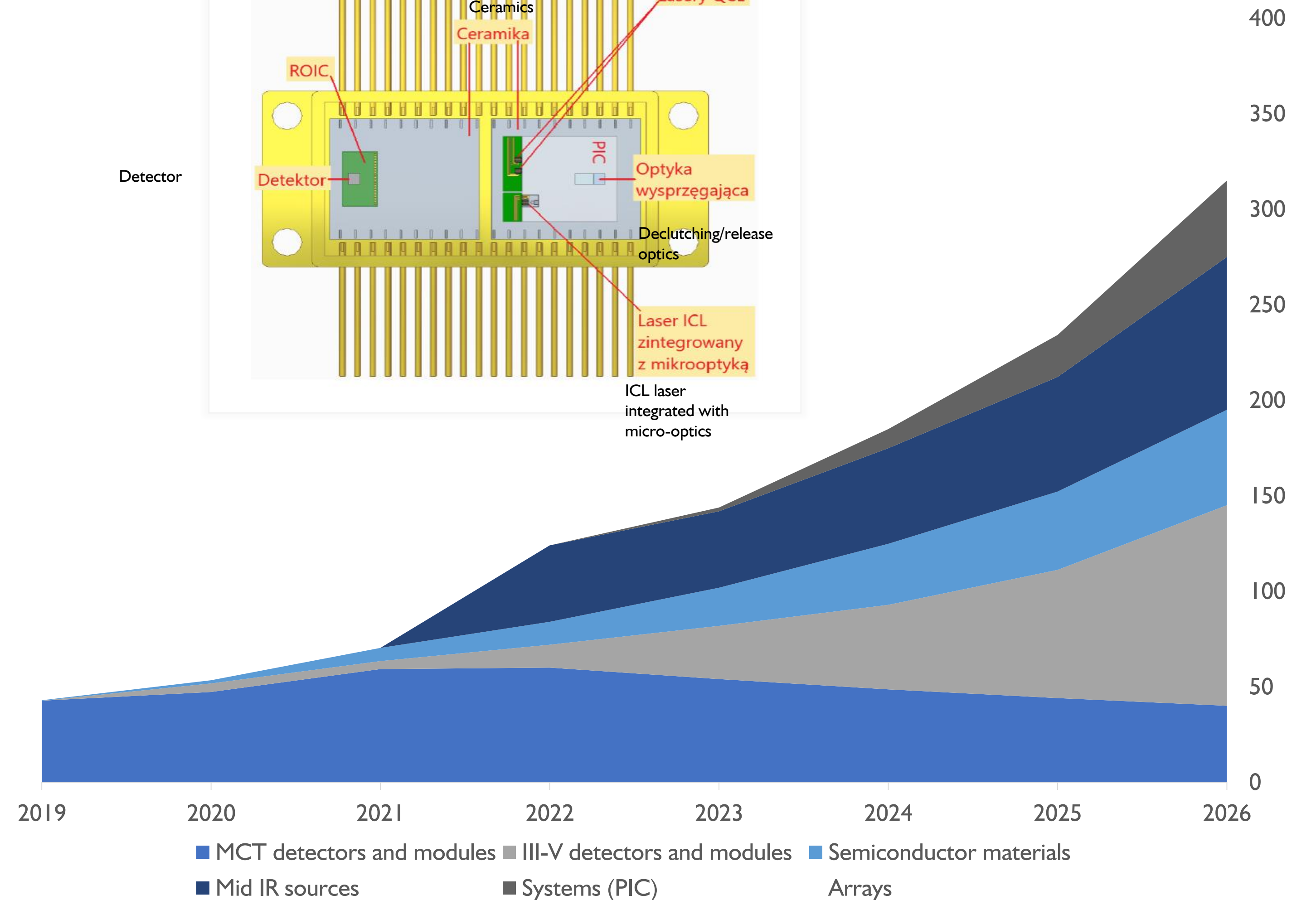
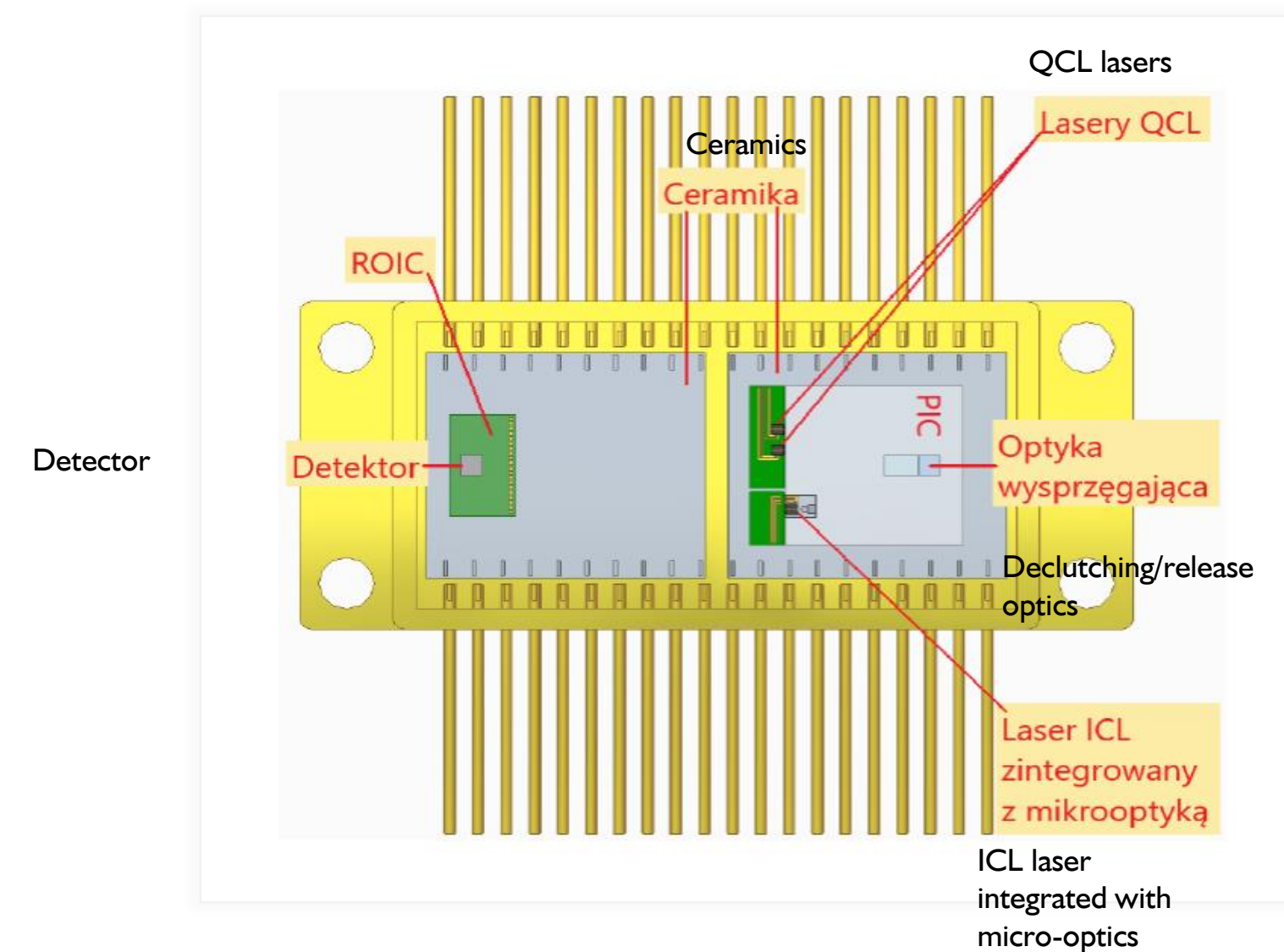

6. INFRARED ARRAYS INITIATIVE

Key assumptions

Determinant factors:

- Area related to the cybersecurity trends, Polonisation of technology and increasing the potential of Polish army,
- Programme requiring a powerful public partner (PGZ or PFR).

Market objective:

- Gaining the position of the main detectors supplier for Polish army/arms industry, acquiring clients outside of Poland (industry, aerospace).

Technological objective:

- Developing a production technology for cooled arrays.

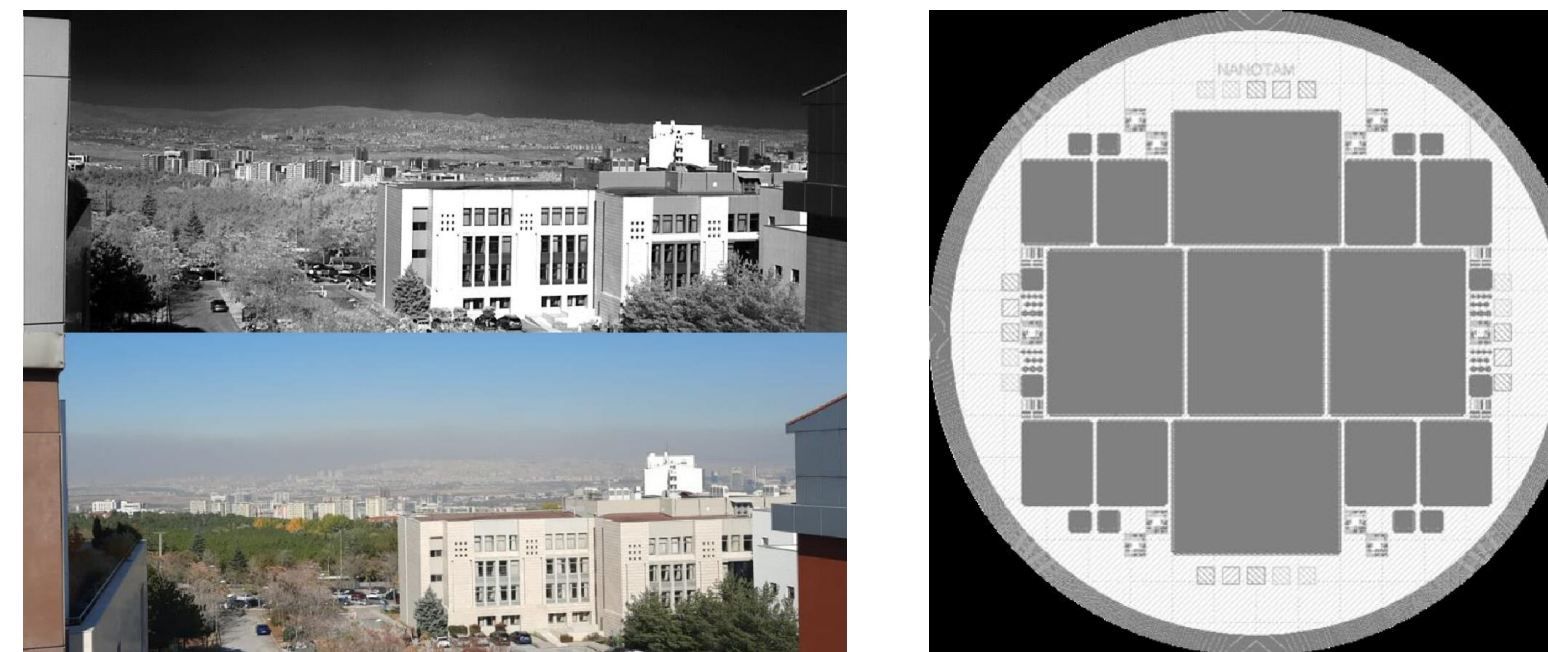
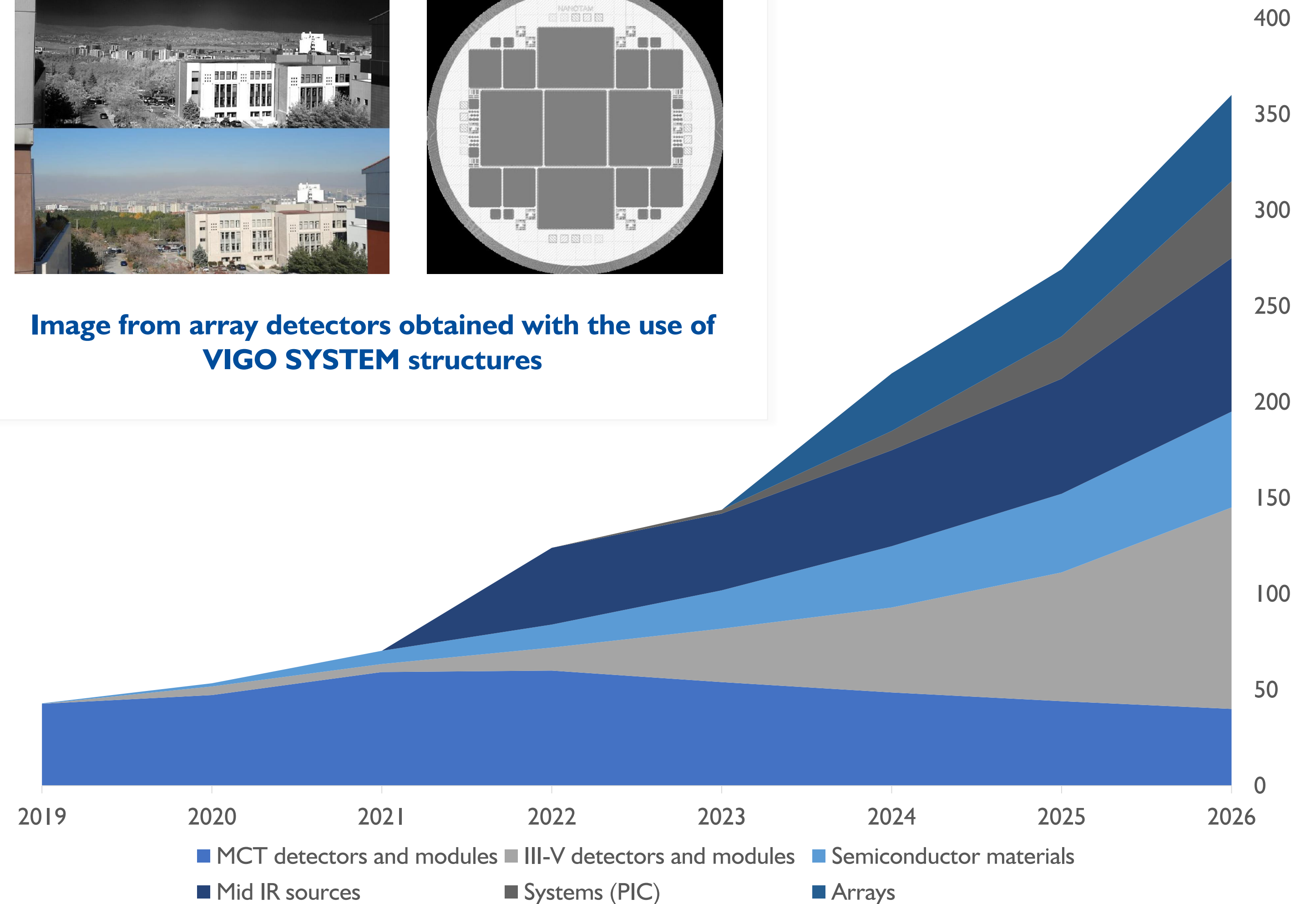

Image from array detectors obtained with the use of VIGO SYSTEM structures



VIGO 2026 STRATEGY GROWTH TARGETS



Changes on the infrared market. Selected trends

VIGO System Evolution

VIGO 2026 Vision

Potential growth paths

2021-2023 FIANANCIAL ASSUMPTIONS

2021-2023 FINANCIAL PERSPECTIVES



Assumptions:

- Slight margin decrease due to i.a. entering new markets,
- Increasing sales budget – new initiatives of exploring new applications and geographic markets,
- Maintaining the level of CAPEX on R&D and infrastructure – 30-40 million annually,
- Maintaining high level of public financing in R&D projects,
- Optimisation of funding sources – maintaining an appropriate debt level,
- Reinvestment of 100% of the generated profit.

Goals:

- Maintaining gross margin >60%
- Maintaining EBITDA profitability >40%
- Accumulated normalised EBITDA for the period 2021 – 2023 > PLN103 million

| [PLN ths] | 2020 | 2021 | 2022 | 2023 |
|-----------------------------|------------|------------|------------|------------|
| Sales revenue | 53 451 | 67 000 | 80 000 | 100 000 |
| Gross profit | 35 615 | 44 890 | 51 200 | 62 000 |
| <i>Gross margin</i> | <i>67%</i> | <i>67%</i> | <i>64%</i> | <i>62%</i> |
| Normalised EBITDA | 24 918 | 29 500 | 33 500 | 40 000 |
| <i>EBITDA profitability</i> | <i>47%</i> | <i>44%</i> | <i>42%</i> | <i>40%</i> |



THANK YOU FOR YOUR ATTENTION!

VIGO System S.A.
ul. Poznańska 129/133
05-850 Ożarów Mazowiecki
POLAND
phone.: +48 22 733 54 10
fax: +48 22 665 21 55
email: info@vigo.com.pl

www.vigo.com.pl