

# AMS-DIG-PROC

## PRELIMINARY DATASHEET

### Signal processing add-on for the AMS detection module series

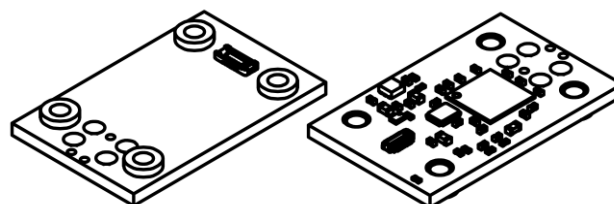

#### FEATURES

- Onboard acquisition and processing
- Fully configurable processing pipeline
- 16bit sampling, 32bit processing
- 7 Msamples/s
- Programmable oversampling
- Multiple processing algorithms
- Trigger output and input
- UART communication interface
- Optional adapter to the 1.27 mm standard header
- Optional USB adapter ([AMS-DIG-USB](#))
- Compatible with the [AMS3140-01](#), [AMS6140-01](#) and their accessories
- Rapid prototyping and proof-of-concept development
- Designed for easy integration with the AMS detection module series and the AMS accessories
- [Python and C libraries](#) including source code

For optimal noise performance, [external amplifiers from AMS accessories](#) are strongly recommended.

#### TABLE OF CONTENTS

FEATURES .....	1
APPLICATIONS.....	1
GENERAL DESCRIPTION .....	1
TABLE OF CONTENTS .....	1
CONNECTIVITY AND ELECTRICAL DIAGRAM .....	2
ABSOLUTE MAXIMUM RATINGS.....	3
SPECIFICATION.....	3
PROCESSING PIPELINE.....	3
COMMUNICATION .....	5
MECHANICAL REQUIREMENTS.....	14
MECHANICAL LAYOUT .....	14

#### APPLICATIONS

- Portable devices
- Temperature and gas sensors
- Embedded systems
- Rapid prototyping

#### GENERAL DESCRIPTION

The AMS-DIG-PROC is a digital accessory for the [AMS detection module series](#). It is designed to be an easy tool for rapid prototyping and proof-of-concept work. It provides standard electrical interfaces and well-documented software protocol to fit all infrared measurement applications.

The AMS-DIG-PROC offers not only analog signal acquisition. It can be used to process data directly on board. Built-in algorithms allow rapid implementation of typical measurement scenarios, including pulsed laser or chopper-based methods.

The output socket of the AMS-DIG-PROC offers serial communication as well as trigger input and output. The functions of the pins are shown in TABLE 1.

## CONNECTIVITY AND ELECTRICAL DIAGRAM

There are two sockets placed on the board (see FIGURE 1 and FIGURE 4). P1 is the interface to the AMS module. P2 is the output socket with pinout described in TABLE 1. P2 is rotated 90 degrees relative to P1 to avoid

accidental connection of non-compatible analog accessories from the AMS family. All unused pins of P2 should be left floating. The recommended mating part for P2 is Amphenol 101R014FB110.

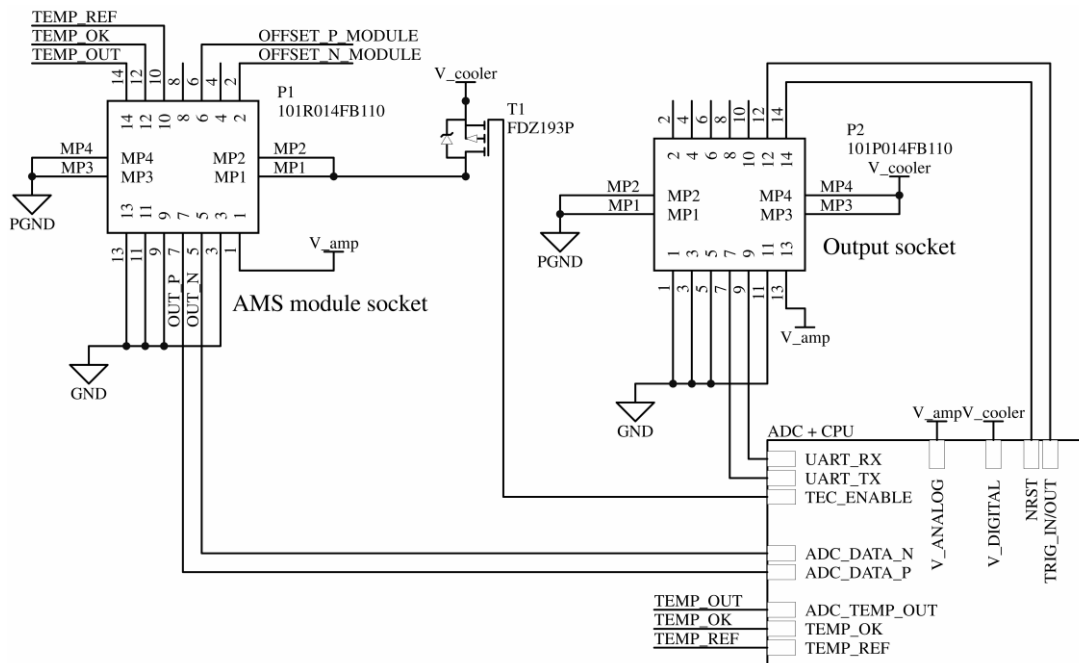

FIGURE 1. Schematic diagram of the AMS-DIG-PROC. All unused pins of P2 should be left floating.

TABLE 1. P2 socket pin functions

Pin number	Symbol	Function
1, 3, 5, 11	GND	Signal ground
2, 4, 6, 8, 10		Reserved. Leave floating
7	UART_TX	UART output of the AMS-DIG-PROC
9	UART_RX	UART input of the AMS-DIG-PROC
12	TRIG_IN/OUT	Trigger input or output
13	V <sub>amp</sub>	Analog supply input
14	NRST	Reset input. Active low
MP1, MP2	PGND	Power ground. Connect to signal ground.
MP3, MP4	V <sub>cooler</sub>	Power supply for the cooler of the AMS module and digital logic of AMS-DIG-PROC

The digital part of the ADC+CPU block is supplied from the V<sub>cooler</sub> which is also passed to the AMS module using a T1 transistor allowing programmable enabling/disabling of the cooler circuit built into the

AMS module. The V<sub>amp</sub> is used to supply analog circuits and is also passed to the AMS module to supply its amplifiers.

## ABSOLUTE MAXIMUM RATINGS

Do not stress the device above the limits specified in this chapter since it may cause permanent damage to the device.

TABLE 2. Absolute maximum ratings

Parameter	Rating
Amplifier supply, $V_{amp}$ , $V_{cooler}$	3.5 V
TRIG_IN voltage	0 V to 5.0 V
NRST voltage	0 V to ( $V_{cooler} + 0.2$ ) V
UART_RX/TX voltage	0 V to 3.5 V
Ambient operating temperature, $T_{amb}$	-40°C to 65°C, non-condensing
Storage temperature, $T_{stg}$	-50°C to 85°C

## SPECIFICATION

TABLE 3. AMS-DIG-PROC specification (+3.3 V supply,  $T_{amb} = 20^\circ\text{C}$ , unless otherwise noted)

Parameter	Test conditions/remarks	Value			Unit
		Min.	Typ.	Max.	
<b>ANALOG</b>					
$V_{amp}$ current, $I_{amp}$	Without additional boards		5		mA
$V_{cooler}$ current, $I_{cooler}$	Without additional boards		120		mA
<b>DIGITAL</b>					
Sampling rate, $f_s$			7		MHz
ADC Resolution			16		bits
Processing resolution			32		bits
Trigger out low level, $V_{OL}$				0.4	V
Trigger out high level, $V_{OH}$		2.9			V
Trigger in low level, $V_{IL}$				1.22	V
Trigger in high level, $V_{IH}$		2.31			V
Default UART bitrate			1		Mbit/s

## PROCESSING PIPELINE

Built-in processing pipeline provides onboard configurable 32-bit algorithms. The processing logic is presented in FIGURE 2, while its architecture is presented in FIGURE 3.

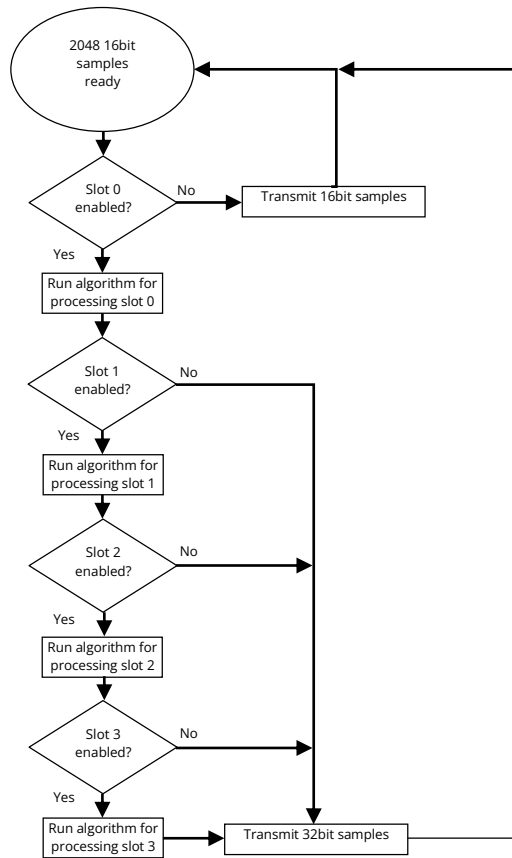

FIGURE 2. Processing pipeline logic



FIGURE 3. Processing pipeline architecture

After acquisition with built-in ADC data are passed to the first processing slot. Buffer size between acquisition and processing is fixed and contains 2048 16-bit samples.

There are 4 processing slots available. Each of them is fully configurable. For all available processing algorithms please refer to chapter COMMUNICATION.

Processing can be also disabled to provide the fastest possible data rate. However, in this setup data loss will occur due to the limited bandwidth of communication interfaces. Therefore it is highly recommended to use as many processing capabilities as possible to avoid high data rates transmissions.

First disabled (not configured) processing slot will pass data directly to the transmission block. Therefore it is required to configure slots starting from slot 0 and use always adjacent slots without any gap between them.

Output buffer size from the processing slot depends on its configuration. Some processing algorithms produce up to 2048 samples, while others generate just 1 sample. For more information please refer to chapter COMMUNICATION.

## COMMUNICATION

### INTRODUCTION

The communication interface for the AMS-DIG-PROC board is 3.3V UART, 8 bits, no parity, 1 stop bit. Default speed is 1 Mbit/s.

Please keep in mind that there are [Python and C API](#) available and their use is strongly recommended. They come with a lot of [examples](#) for typical use cases of AMS-DIG-PROC.

### PACKETS AND FRAMING

In critical applications, consistency of transmitted data is crucial to guarantee the necessary safety level. Therefore AMS-DIG-PROC uses Consistent Overhead Byte Stuffing ([COBS](https://en.wikipedia.org/wiki/Consistent_Overhead_Byte_Stuffing), [https://en.wikipedia.org/wiki/Consistent\\_Overhead\\_Byte\\_Stuffing](https://en.wikipedia.org/wiki/Consistent_Overhead_Byte_Stuffing)) packet framing and [CRC32/POSIX](#) checksum on the data-link layer for any communication interface. The format of the packet and message is presented in TABLE 4.

TABLE 4. Packet and message format

COBS packet	Content		Length in bytes
SOP (Start of Packet)	(0x00 to 0xFF, see <a href="#">COBS</a> )		1
Message, COBS encoded	Header	CRC	4
		MessageID	1
	Payload		(Variable)
EOP (End of Packet)	0x00		1

Generally there are no acknowledgments. The module does not sent any direct response to most messages, except MESSAGE\_CONFIG\_READ, MESSAGE\_MODE\_READ and MESSAGE\_PROCESSING\_READ.

### STATUS

Status contains all important information about the current state of the AMS-DIG-PROC. It will be sent periodically once per second regarding any configuration option.

TABLE 5. Output message: status

Field	Length in bytes	Values	Description or constant name
CRC	4	-	
MessageID	1	120	MESSAGE_STATUS
ResetFlag	1	1 – Reset occurred 0 – Reset not occurred	Can be cleared with a MESSAGE_CLEAR_RESET_FLAG message
ConfigurationUnsaved	1	1 – Configuration changed since last saving 0 – Configuration unchanged since last saving	Will be set to 1 after changing any configuration parameter Will be set to 0 after configuration save or after reboot
SamplingState	1	0 – Sampling stopped 1 – Sampling in progress 2 – Waiting for the trigger	
ProcessingState	1	0 – Processing idle or disabled 1 – Processing in progress	
DataOverflowCounter	4	0 after reboot	Type: uint32_t Will be incremented after overflow
MessagesReceivedCounter	4	0 after reboot	Type: uint32_t Will be incremented after receiving each correct message
DetectorTemperature	4		Type: uint32_t Units: mK
TemperatureOK	1	0 – Temperature not reached or not stable 1 – Temperature is stable and close to expected	

## CLEARING RESET FLAG

Clearing the reset flag in the STATUS message allows the detection of unexpected reboot of the AMS-DIG-PROC.

TABLE 6. Input message: clear reset flag

Field	Length in bytes	Values	Description or constant name
CRC	4	-	
MessageID	1	125	MESSAGE_CLEAR_RESET_FLAG

## REBOOT

This message forces AMS-DIG-PROC to reboot. The ResetFlag in the STATUS message will be set to 1. Configuration will be read from nonvolatile memory and work mode STOP will be enabled.

TABLE 7. Input message: reboot

Field	Length in bytes	Values	Description or constant name
CRC	4	-	
MessageID	1	124	MESSAGE_REBOOT

## CONFIGURATION

Configuration is a special subset of messages for which transmitted parameters can be saved to nonvolatile memory. Default values for each parameter are bolded.

## Communication interfaces

TABLE 8. Input/output message: communication channel and parameters

Field	Length in bytes	Values	Description or constant name
CRC	4	-	
MessageID	1	50	MESSAGE_CONFIGURE_COMMUNICATION
UartBaud	4	9600 57600 115200 <b>1000000</b>	Type: uint32_t Unit: bps

## Sampling and processing resolution

TABLE 9. Input/output message: sampling parameters

Field	Length in bytes	Values	Description or constant name
CRC	4	-	
MessageID	1	51	MESSAGE_CONFIGURE_SAMPLING
PhysicalSampleRate	4	700000 to <b>7000000</b>	Type: uint32_t Unit: samples per second Leave default 7000000 in most scenarios
PhysicalResolution	1	<b>2 - 16 bit</b>	Fixed to 16bits. Leave default
ProcessingResolution	1	<b>4 - 32 bit</b>	Fixed to 32bits. Leave default

## Temperature of the detector

TABLE 10. Input/output message: temperature of the detector

Field	Length in bytes	Values	Description or constant name
CRC	4	-	
MessageID	1	52	MESSAGE_CONFIGURE_DETECTOR_TEMPERATURE
Temperature	2	200-400 or 0 <b>Default: 273</b>	Type: uint16_t Units: K Set to zero to disable the temperature controller

## User space

User space is a space which can be freely modified by the host. It can be used for any kind of data, i.e. calibration parameters, UID storage, etc.

TABLE 11. Input/output message: setting user space content

Field	Length in bytes	Values	Description or constant name
CRC	4	-	
MessageID	1	53	MESSAGE_CONFIGURE_USER_SPACE
Data	256	-	

## Saving configuration

The AMS-DIG-PROC will perform a reboot after saving the configuration. To be sure that a valid configuration has been stored in nonvolatile memory it is recommended to read configuration after reboot.

TABLE 12. Input message: saving configuration into nonvolatile memory

Field	Length in bytes	Values	Description or constant name
CRC	4	-	
MessageID	1	55	MESSAGE_CONFIG_SAVE

## Reading configuration

Once the configuration has been set and/or saved, it is recommended to read its content to verify if all parameters were set to desired values. The response for this message will have the same format as presented before.

TABLE 13. Input message: reading configuration

Field	Length in bytes	Values	Description or constant name
CRC	4	-	
MessageID	1	56	MESSAGE_CONFIG_READ
ConfigID	1	MESSAGE_CONFIGURE_COMMUNICATION MESSAGE_CONFIGURE_SAMPLING MESSAGE_CONFIGURE_DETECTOR_TEMPERATURE MESSAGE_CONFIGURE_USER_SPACE	Defines which configuration will be read

## Work modes

The AMS-DIG-PROC can work in different modes of operation, called work modes. Their purpose is to implement typical use cases for infrared measurements, like working with choppers or pulsed laser sources. Unlike configuration, work mode has to be configured after each reset of the AMS-DIG-PROC board.

By default the AMS-DIG-PROC board enter STOP mode after each boot.

### Work mode: Stop

In this work mode data acquisition and processing are stopped. This is default mode for AMS-DIG-PROC board after booting.

TABLE 14. Entering STOP work mode

Field	Length in bytes	Values	Description or constant name
CRC	4	-	
MessageID	1	3	MESSAGE_MODE_STOP

### Work mode: Free running

This is simplest work mode with continuous data acquisition. No synchronization with external signals is available in this mode.

TABLE 15. Input/output message: FREERUNNING work mode

Field	Length in bytes	Values	Description or constant name
CRC	4	-	
MessageID	1	5	MESSAGE_MODE_FREE_RUNNING
Number of samples	4	0x00: Infinity Other: number of samples	Number of samples. Has to be multiple of 2048. When set to non-zero value, sampling process will stop and module will enter STOP mode. Keep in mind that this is not necessary the length of data reported in MESSAGE_OUTPUT_DATA message. If Number of samples does not fit into the output buffer (8192 bytes) then data will be splitted into multiple messages with output data. Overrun may occur, but the processing pipeline can also reduce the number of samples (i.e. oversampling or averaging). If set to 0, sampling will stop only after receiving Stop Mode request.



### Work mode: Trigger input

This mode is very similar to typical operation of an oscilloscope. The AMS-DIG-PROC waits for rising edge on TRIG\_IN/OUT signal. Optional delay after trigger event can be configured. After the delay AMS-DIG-PROC starts sampling data. Sampling process is stopped after acquiring the requested number of samples and the module waits for the next trigger event.

TABLE 16. Input/output message: TRIGGER INPUT work mode

Field	Length in bytes	Values	Description or constant name
CRC	4	-	
MessageID	1	6	MESSAGE_MODE_TRIGGER_INPUT
Number of samples	4	$\geq 2048$	Type: uint32_t Total number of samples to be acquired for a single trigger event. Has to be a multiple of 2048.
Delay	4	0 to 1e7	Type: uint32_t Unit: microseconds Set to zero to disable the delay between trigger event and start of ADC sampling
Edge	1	1 - rising edge	Only rising edge is currently implemented

### Work mode: Trigger output

This mode allows external sources of radiation (like pulsed lasers) to be triggered from the module. In comparison to trigger input, this work mode provides lowest possible jitter and therefore is recommended with fast pulsed sources. Optional delay can be set to introduce time offset between generated trigger event and start of sampling.

TABLE 17. Input/output message: TRIGGER OUTPUT work mode

Field	Length in bytes	Values	Description or constant name
CRC	4	-	
MessageID	1	7	MESSAGE_MODE_TRIGGER_OUTPUT
Number of samples	4	$\geq 1$	Type: uint32_t Total number of samples to be acquired for a single trigger event. Has to be a multiple of 2048.
Delay	4	0 to 1e7	Type: uint32_t Unit: microseconds Time between start of ADC sampling and trigger event. Set to zero to start ADC together with generated trigger event.
Period	4	0 to 1e7	Type: uint32_t Unit: microseconds Actual period can be higher than set due to configuration of processing.
Edge	1	1 - rising edge	Only rising edge is currently implemented

### Work mode: Simulation

This mode is useful for testing purposes. Instead of sampled data simulated values will be sent to processing pipeline periodically. Addition of random can be activated to verify if processing was properly configured.

TABLE 18. Input/output message: SIMULATION work mode

Field	Length in bytes	Values	Description or constant name
CRC	4	-	
MessageID	1	8	MESSAGE_MODE_SIMULATION
SamplesCount	4	2048	Type: uint32_t Total number of samples that will be sent to processing pipeline. Currently fixed to 2048 samples.
SampleSize	1	2 : 16 bit	SampleSize is fixed to 16bit.
NoiseRMS	4	0 - 65535.	Type: float32 Gaussian white noise with this RMS value will be added to samples. Set to zero to disable addition of noise.
Period	4	>0	Type: uint32_t Unit: ms Time interval between sending simulated samples to processing pipeline.
Samples	N		Type: uint16_t[N] Samples will be used instead of ADC samples. Single buffer. N*2 should match SamplesCount value.

### Reading current work mode settings

Once work mode has been set it is recommended to read its settings to verify if all parameters were set correctly. The response for this message will be one of described above messages: MESSAGE\_MODE\_STOP, MESSAGE\_MODE\_FREE\_RUNNING, MESSAGE\_MODE\_TRIGGER\_INPUT, MESSAGE\_MODE\_TRIGGER\_OUTPUT, MESSAGE\_MODE\_SIMULATION.

TABLE 19. Input message: reading work mode settings

Field	Length in bytes	Values	Description or constant name
CRC	4	-	
MessageID	1	100	MESSAGE_MODE_READ

## PROCESSING ALGORITHMS

Processing algorithms can be configured and assigned to each processing slot individually. Several algorithms are available, however not every combination of them makes sense. Therefore example configurations will be presented at the end of this chapter.

Processing can be reconfigured only in STOP work mode.

### No processing

This is the default “algorithm” assigned to each processing slot after power-up. All data are passed through processing slot without any modification.

Output buffer length and sample size are equal to the input buffer length and sample size.

TABLE 20. Input/output message: No processing for a processing slot

Field	Length in bytes	Values	Description or constant name
CRC	4	-	
MessageID	1	9	MESSAGE_PROCESSING_NONE
SlotID	1	0 to 3	

### Simple average

All samples from the input buffer are averaged and passed as single value to the output buffer.

Output buffer length is equal to 1.

Output sample size: 32bits.

TABLE 21. Input/output message: simple average for a processing slot

Field	Length in bytes	Values	Description or constant name
CRC	4	-	
MessageID	1	10	MESSAGE_PROCESSING_SIMPLE_AVERAGE
SlotID	1	0 to 3	

### Sample-wise iir filter

Average is averaged using infinite impulse response filter according to the following formula:

$$X = X_{\text{previous}} * \text{weight} + X_{\text{new}} * (1 - \text{weight})$$

Output buffer length: 1.

Output sample size: 32bits.

TABLE 22. Input/output message: sample-wise IIR filter for a processing slot

Field	Length in bytes	Values	Description or constant name
CRC	4	-	
MessageID	1	11	MESSAGE_PROCESSING_SAMPLE_IIR
SlotID	1	0 to 3	
Weight	4	0.0 to 1.0	Type: float32

### Buffer-wise iir filter

Every n-th sample of the input buffer is averaged with n-th sample from the previous result. This algorithm is especially useful in triggered work modes. This kind of processing reduces noise while keeping the original shape of the detected pulse.

Output buffer length: length of the input buffer.

Output sample size: 32bits.

TABLE 23. Input/output message: buffer-wise IIR filter for a processing slot

Field	Length in bytes	Values	Description or constant name
CRC	4	-	
MessageID	1	12	MESSAGE_PROCESSING_BUFFER_IIR
SlotID	1	0 to 3	
Weight	4	0.0 to 1.0	Type: float32

### Oversampling

Averages N consecutive samples in the input buffer. Reduces output data rate in a configurable way.

Output buffer length: value of *OutputSamples* parameter. CAUTION: *Ratio \* OutputSamples* has to be a multiple of input buffer length

Output buffer length: variable.

Output sample size: 32bits.

TABLE 24. Input/output message: oversampling for a processing slot

Field	Length in bytes	Values	Description or constant name
CRC	4	-	
MessageID	1	13	MESSAGE_PROCESSING_OVERSAMPLING
SlotID	1	0 to 3	
Ratio (N)	4	2 to 8388608	Type: uint32_t <i>Ratio * OutputSamples</i> has to be multiple of input buffer length
OutputSamples	4	1 to 2048	Type: uint32_t <i>Ratio * OutputSamples</i> has to be multiple of input buffer length

### Peak-peak measurement

Extracts peak-peak value from the input buffer.

Output buffer length: 1.

Output sample size: input buffer sample size.

TABLE 25. Input/output message: peak-peak measurement for a processing slot

Field	Length in bytes	Values	Description or constant name
CRC	4	-	
MessageID	1	14	MESSAGE_PROCESSING_PEAK_PEAK
SlotID	1	0 to 3	

### Buffer-wise decimation

Drops whole buffers. Passes only N-th buffer from input to output.

Output buffer length: length of the input buffer or zero for dropped buffers.

Output sample size: Input buffer sample size.

This type of processing may be useful e.g. in case of buffer-wise filter. Usually not every buffer need to be transmitted since the content of each buffer changes slowly.

Usually not all buffers may be sent due to limits of communication channels. Buffer-wise decimation allows proper handling of *Counter* field in output data message.

TABLE 26. Input/output message: buffer-wise decimation of data

Field	Length in bytes	Values	Description or constant name
CRC	4	-	
MessageID	1	15	MESSAGE_PROCESSING_BUFFER_DECIMATION
SlotID	1	0 to 3	
Ratio (N)	4	$\geq 2$	Type: uint32_t For example: 4 means that every 4 <sup>th</sup> buffer will be sent to the output

### Reading processing configuration

Once processing configuration has been set, it is recommended to read current configuration to verify if all parameters have correct values. The response will have the same format as request of specific processing configuration presented before.

TABLE 27. Input message: reading configuration for a slot

Field	Length in bytes	Values	Description or constant name
CRC	4	-	
MessageID	1	105	MESSAGE_PROCESSING_READ
SlotID	1	0 to 3	

### OUTPUT DATA

Once properly configured (e.g. work mode is set to freerunning) the AMS-DIG-PROC will send periodically output data. Length of data is variable and depends on the current configuration of the processing pipeline. On the receiver side length can be extracted utilizing features of COBS encoding.

TABLE 28. Output message: output data sent by AMS-DIG-PROC

Field	Length in bytes	Values	Description or constant name
CRC	4	-	
MessageID	1	90	MESSAGE_OUTPUT_DATA
Counter	1		Will be incremented for each output data message. Can be used to check for data loss due to communication errors or processing overflow. In case of buffer decimation in processing pipeline it will be incremented by ratio of decimation.
SampleSize	1	1 – 8bit 2 – 16bit 4 – 32bit	Sample size depends on processing pipeline configuration. If all processing slots are disabled SampleSize is 2.
Data	1 to 8192	0-255 or 0-65535 or 0- 4294967295	Type: uint8_t, uint16_t or uint32_t, depending on SampleSize. Each data sample has offset equal to half of the range. For example for 8bit SampleSize value 128 should be interpreted as zero. Higher values correspond to positive values while lower are negative. The length of Data will be between 1 and 2048, depending on the configuration of processing pipeline. If processing is disabled, length of the data is 4096 bytes.

Conversion from Data (raw samples) to voltages for i-th sample can be done using the following generic formula:

$voltage = (data8[i] * 2.0 / 255 - 1) * 3.3$  // For 8-bit samples

$voltage = (data16[i] * 2.0 / 65535 - 1) * 3.3$  // For 16-bit samples

$voltage = (data32[i] * 2.0 / 4294967295 - 1) * 3.3$  // For 32-bit samples

where data8, data16 and data32 are elements from Data casted to a proper type according to SampleSize.

### Examples

1. Continuous temperature measurement couple times a second
  - a. Workmode: freerunning
  - b. Processing slot 0: oversampling (Ratio=4096, OutputSamples=2048)
  - c. Processing slot 1: oversampling (Ratio=512, OutputSamples=1)
2. Pulsed laser source. Duration of single pulse: 1ms. Rise and fall time: 0.1 ms.
  - a. Workmode: trigger input or output
  - b. Processing slot 0: oversampling (Ratio=8, OutputSamples=2048)
  - c. Processing slot 1: buffer-wise iir filter (weight=0.95)
3. Black body with chopper. Frequency: 1 kHz. Peak-peak measurement
  - a. Workmode: trigger input
  - b. Processing slot 0: oversampling (Ratio=8, OutputSamples=2048)
  - c. Processing slot 1: peak-peak

For more examples please refer to [API documentation](#).

## MECHANICAL REQUIREMENTS

There are four spacers mounted on the PCB to keep the proper distance between the AMS module (or amplifier) and AMS-DIG-PROC.

Warning! The P1 and P2 sockets are very sensitive to mechanical stress. The AMS-DIG-PROC has to be fixed to the AMS detection module with screws and nuts. Caution is required when assembling the AMS-DIG-PROC with the AMS module.

## MECHANICAL LAYOUT

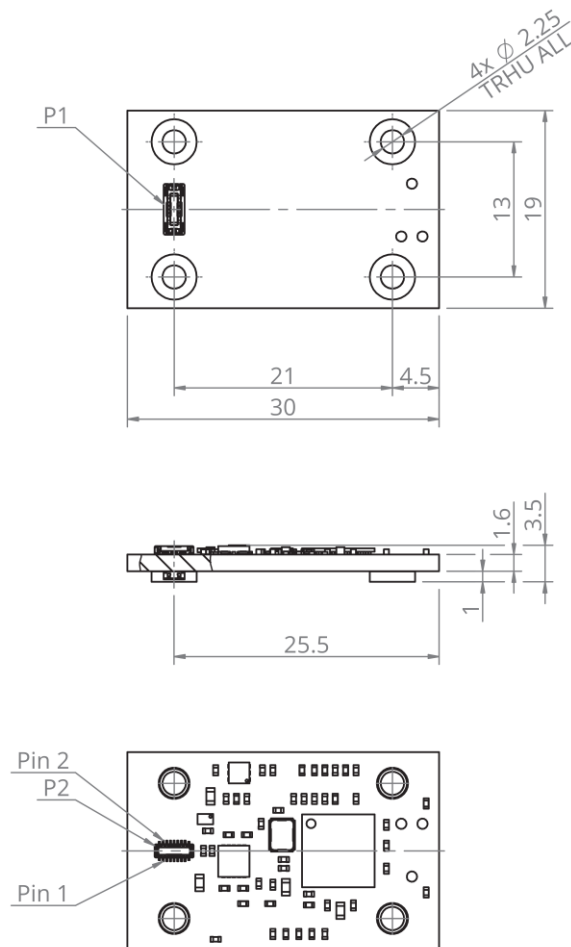

FIGURE 4. Dimensions of the AMS-DIG-PROC (given in mm)