

Bottom view

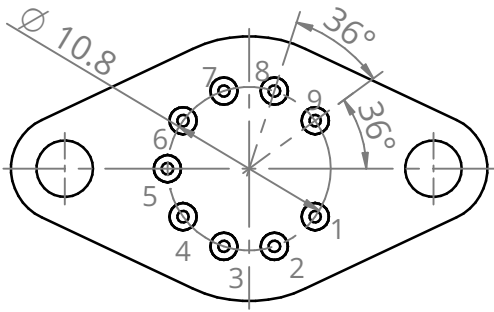

Bottom view
Photoconductive

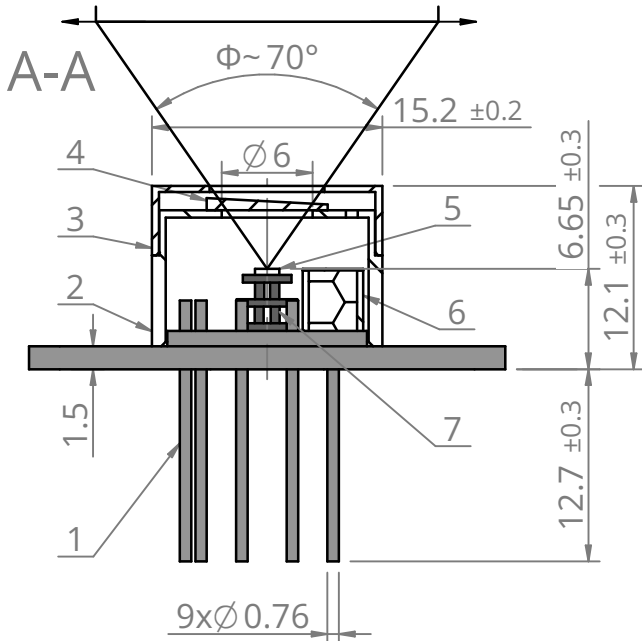
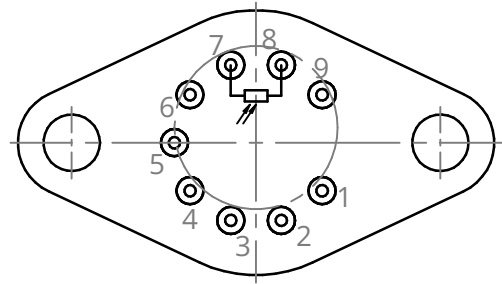

Pinout	
Pin No.	Connection
1	TE cooler (+)
2	Not used
3	Not used
4	Not used
5	Thermistor
6	Thermistor
7	Active element
8	Active element
9	TE cooler (-)

Top view

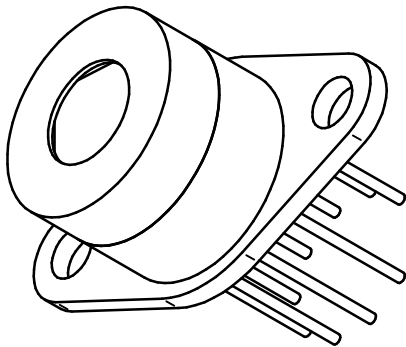
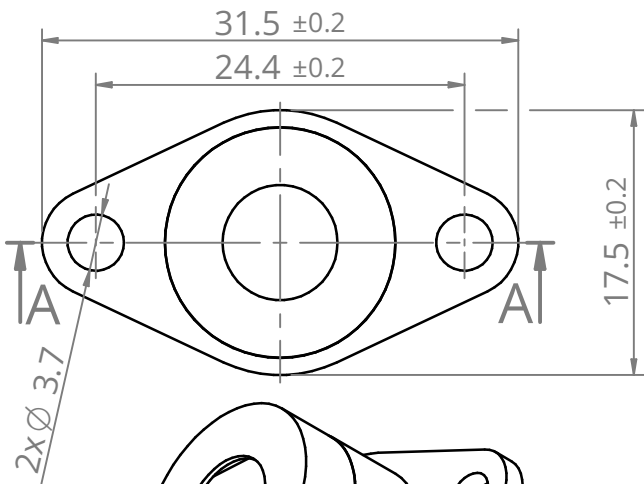

Φ - Acceptance angle

7	Thermoelectric cooler	
6	Humidity absorber container	Stainless steel
5	Active element	HgCdTe/InAs/InAsSb/GaAs
4	Window	Al ₂ O ₃ /ZnSe AR
3	Detector cap	Stainless steel
2	Detector case	Stainless steel
1	TO66 header	Gold plated Kovar
No.	Name	Material

FIRST ANGLE
PROJECTION



UNIT: mm
GENERAL TOLERANCE:
ISO 2768-mK

Scale
2:1

Sheet
1/1

Size
A4

This document is the property of VIGO Photonics S.A. and may not be disclosed to third parties, copied or used in whole or in part for any purpose without written permission from VIGO Photonics S.A.

Date
15.03.2024

Drawing No.
ZTM-TO66-Z022

Rev.
1

Title
2TE-TO66(9p)-wW, PC detector

VIGO
PHOTONICS