

AMS-DIG-USB

PRELIMINARY DATASHEET

USB addon for the AMS-DIG-PROC board

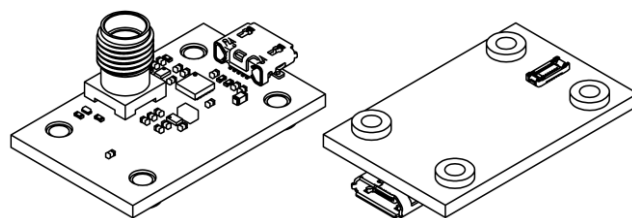

FEATURES

- Compatible with the [AMS-DIG-PROC](#) board
- Communication over the standard USB interface
- Power supply for AMS-DIG-PROC and AMS3140 module with accessories
- Up to 1 Mbit/s transfer rate
- Trigger output and input on the SMA socket
- Designed for easy integration with the AMS detection module series and AMS accessories
- Virtual COM port

APPLICATIONS

- Rapid prototyping
- PC-based measurements in the lab
- Temperature and gas sensors
- Embedded systems

GENERAL DESCRIPTION

The AMS-DIG-USB is a USB adapter for the [AMS-DIG-PROC](#) board. It is designed to be an easy tool for rapid prototyping and proof-of-concept work. It provides communication and power supply over a single USB connector. A virtual serial port (COM port) makes it easy to integrate with PC-based measurement software. From a communication point of view, AMS-DIG-USB is transparent. For details about communication protocol please refer to the AMS-DIG-PROC documentation. SMA connector can work as trigger input as well as output, which enables synchronization with external signals.

CONNECTIVITY

Just two connectors are available for the user: USB for communication and SMA for external trigger. A generic electrical diagram is presented in FIGURE 1. A detailed schematic is available on request. Please contact our tech support team for more details.

TABLE OF CONTENTS

FEATURES	1
APPLICATIONS.....	1
GENERAL DESCRIPTION	1
CONNECTIVITY	1
TABLE OF CONTENTS	1
ELECTRICAL DIAGRAM.....	2
ABSOLUTE MAXIMUM RATINGS.....	3
SPECIFICATION.....	3
MECHANICAL REQUIREMENTS.....	4
MECHANICAL LAYOUT	4

ELECTRICAL DIAGRAM

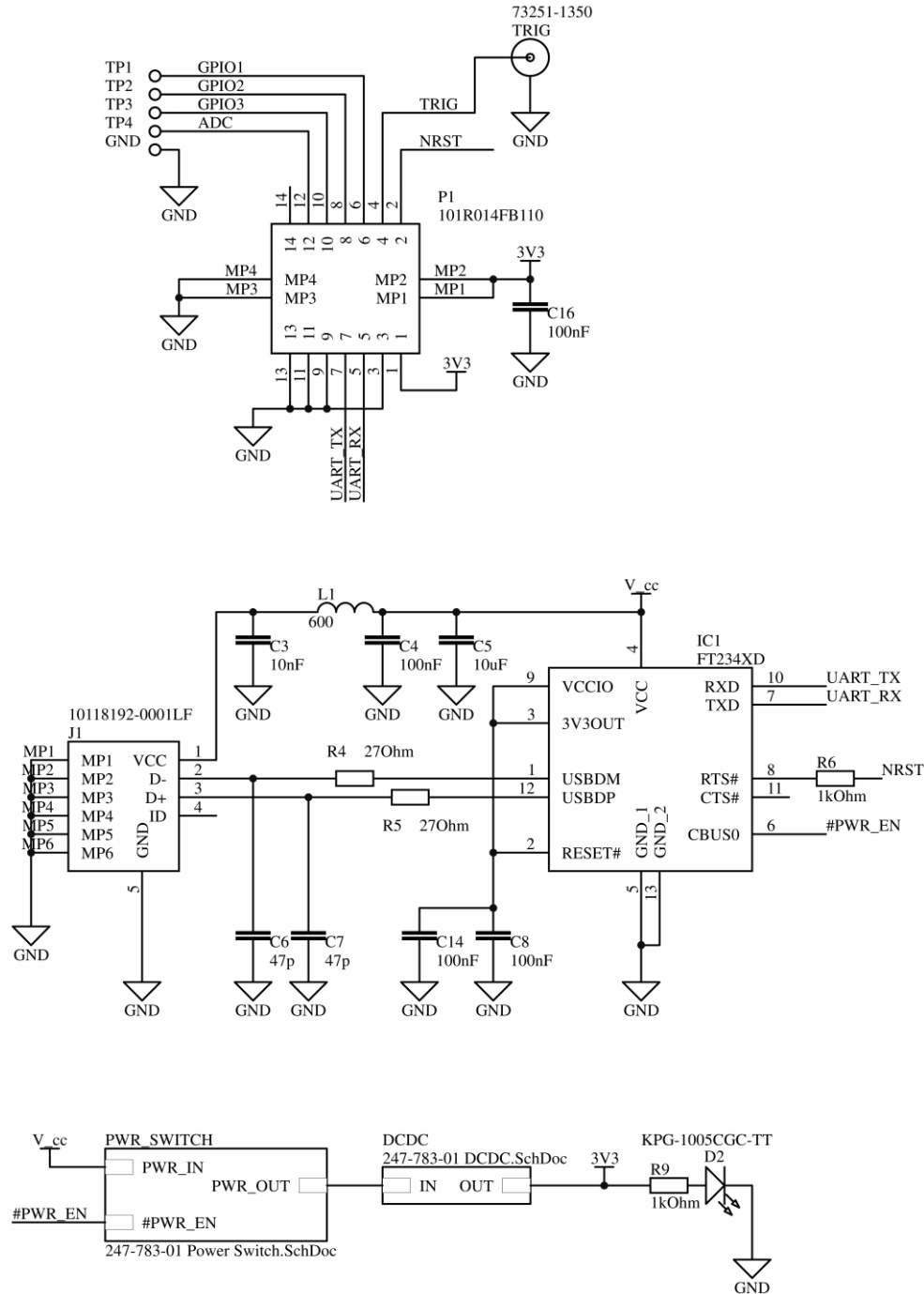

FIGURE 1. Schematic diagram of the AMS-DIG-USB

ABSOLUTE MAXIMUM RATINGS

Do not stress the device above the limits specified in this chapter since it may cause permanent damage to the device.

TABLE 1. Absolute maximum ratings

Parameter	Rating
TRIG_IN voltage	0 V to 3.3 V
Ambient operating temperature, T_{amb}	-40°C to 65°C, non-condensing
Storage temperature, T_{stg}	-50°C to 85°C

SPECIFICATION

TABLE 2. AMS-DIG-USB specification. +3.3 V supply, $T_{amb} = 20^{\circ}\text{C}$, unless otherwise noted.

Parameter	Test conditions/remarks	Value			Unit
		Min.	Typ.	Max.	
ANALOG					
V_{cc} current	Without additional boards		10		mA
V_{cc} current	With AMS3140 module (maximum cooling performance) + AMS-EXT-AMP + AMS-DIG-PROC		500		mA
DIGITAL					
Maximum baudrate				1	Mbit/s

For optimal noise performance [external amplifiers from AMS accessories](#) are strongly recommended.

MECHANICAL REQUIREMENTS

There are four spacers mounted on the PCB to keep the proper distance between the AMS-DIG-USB and underlying boards.

Warning! The P1 socket is very sensitive to mechanical stress. The AMS-DIG-USB has to be fixed to the AMS-DIG-PROC board with screws and nuts. Caution is required when assembling the AMS-DIG-USB with the underlying boards.

MECHANICAL LAYOUT

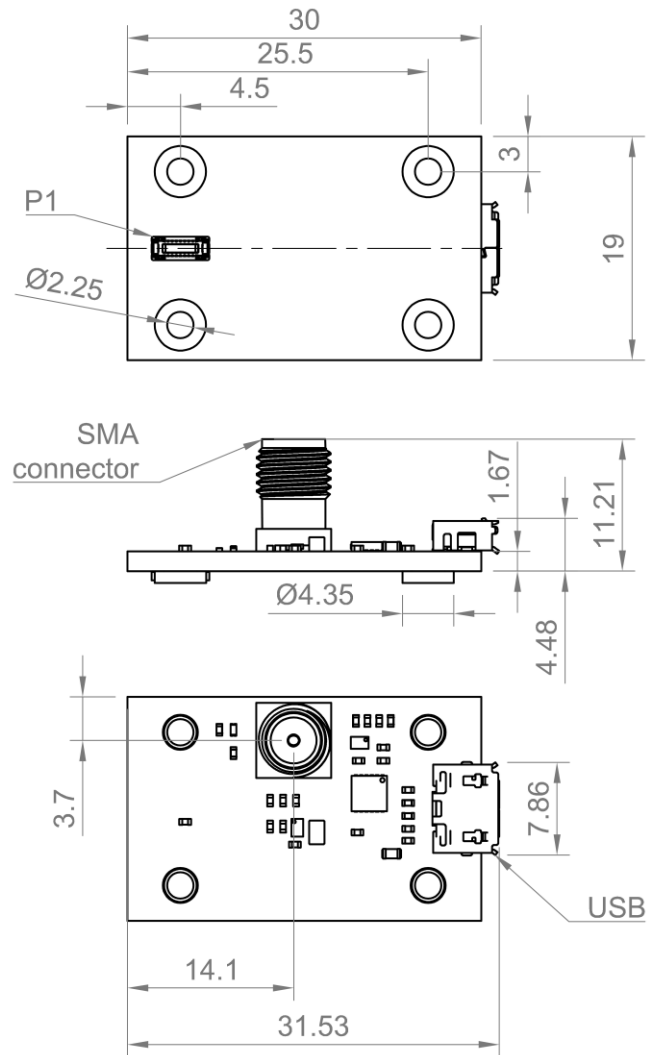

FIGURE 2. Dimensions of the AMS-DIG-USB (given in mm)